



Attrezzature Professionali per Posatori PROFESSIONAL TOOLS FOR TILE LAYERS

SINCE 1946



KAT-LIST 44|18

01 LUGLIO 2016 > 01 LUGLIO 2017

Aggiornato Gennaio 2017 - Update January 2017



 Brevetti Montolit S.p.A. si occupa dal 1946 della progettazione, produzione e commercializzazione di attrezzature professionali per la lavorazione e la posa di ceramica e pietre naturali. Tutti i prodotti della gamma sono coperti, interamente o in parte, da brevetti nazionali o internazionali allo scopo di proteggere e tutelare gli interessi dei Clienti che possono così contare su prodotti unici.

Dalle prime semplici ma ingegnose “macchine” manuali per il taglio e la foratura di materiali come marmo e granito, si è passati nel tempo a soluzioni più complesse (sempre esclusive) per la lavorazione di ogni tipo di ceramica, gres porcellanato o materiale lapideo.

Nei primi anni novanta, Brevetti Montolit è entrata, come protagonista, anche nel contrastato mercato dell’utensile diamantato ed è ora in grado di competere con i leader a livello internazionale. Per la genialità delle idee, la robustezza, qualità e durata dei prodotti, sono stati conferiti a Brevetti Montolit S.p.A. diversi riconoscimenti internazionali tra cui l’ambito Premio Europeo “Mercurio d’oro” ed il premio Mondiale “Ercole d’oro”.

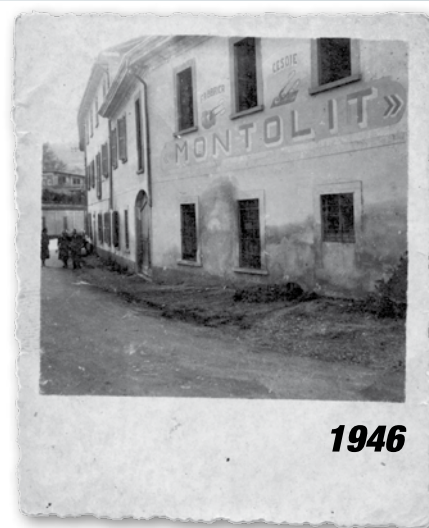

1946

 *The story of Brevetti Montolit™ begins in Italy in 1946; its inception was in a small, highly specialized workshop in Northern Italy for the design and production of building tools.*

Over 70 years later, still operating under the skilled hand of the Montoli family, Montolit™ has become leader in the Italian tiling tools market, sold in over 80 countries worldwide.

Several technical partnerships with International Tiling Schools, Universities and Ceramic tiles Factories keep Brevetti Montolit ahead of tiling tools evolving trends, producing equipment that stands out for its advanced technical solutions, robustness, and long life.

 L’histoire de Brevetti Montolit™ commence en Italie en 1946 dans un petit atelier, hautement spécialisé dans le Nord de l’Italie pour la conception et la production d’outils de construction. Plus de 70 ans plus tard et toujours en activité sous la main habile de la famille Montoli, l’entreprise Montolit™ est devenue leader du marché italien des outils de carrelage, vendu dans plus de 80 pays dans le monde entier.

Plusieurs partenariats techniques avec les écoles de carrelage international, les universités et les usines de carrelage en céramique permettent à Brevetti Montolit de garder une longueur d’avance sur les tendances de l’évolution des outils de carrelage, en produisant des équipements qui se distinguent par ses solutions techniques avancées, la robustesse et une longue durée de vie.



1970

 *Die Geschichte von Brevetti Montolit™ beginnt 1946 in Italien; am Anfang stand eine kleine, hoch spezialisierte Werkstatt in Norditalien für die Entwicklung und die Fertigung von Bauwerkzeugen.*

Über 70 Jahre später, immer noch unter der geschickten Leitung der Familie Montoli, ist Montolit™ zum führenden Unternehmen des italienischen Marktes der Fliesenleger-Werkzeuge geworden, die in über 80 Ländern weltweit verkauft werden.

Zahlreiche Partnerschaften mit internationalen Fliesenleger-Schulen, Universitäten und Keramikfliesen-Herstellern lassen Brevetti Montolit an der Spitze der Entwicklungstendenzen von Fliesenleger-Werkzeugen stehen, indem es Geräte produziert, die sich aufgrund ihrer fortgeschrittenen technischen Lösungen, robusten Bauweise und Langlebigkeit auszeichnen.

2016



MASCHINEN UND AUSRÜSTUNGEN • MACHINES ET OUTILLAGE • MACHINES AND EQUIPMENT • MACCHINE ED ATTREZZATURE



TAGLIAPIASTRELLE MANUALI
MANUAL TILE CUTTERS
DÉCOUPEUSE À CARREAUX MANUEL
MANUELLE FLIESENSCHNEIDER

pag. 6



ATTREZZATURE PER GRANDI FORMATI
EQUIPMENT FOR GIANT TILES
ÉQUIPEMENT POUR LES CARREAUX GÉANTS
AUSRÜSTUNG FÜR GROSSE-FLIESEN

pag. 16



ATTREZZATURE ELETTRICHE
ELECTRIC EQUIPMENT
ÉQUIPEMENT ELECTRIQUE
ELEKTRISCHE AUSRÜSTUNG

pag. 24



TRANCIABLOCCHI
PAVING BLOCK CUTTERS
DÉCOUPEUSE A DALLES ET A PAVE
GEHWEG-PLATTENSALTER

pag. 36



ACCESSORI PER LA POSA
ACCESSORIES FOR THE LAYING OF TILES
ACCESSOIRES POUR LA POSE
ZUBEHÖR FÜR DAS VERLEGEN VON FLIESEN

pag. 42



LAME CIRCOLARI PER LEGNO
CIRCULAR BLADES FOR TIMBER
LAMES CIRCULAIRES POUR LE BOIS
KREISSÄGEBLÄTTER FÜR HOLZ

pag. 47

DIAMANTWERKZEUGE • OUTILS DIAMANTÉS • DIAMOND TOOLS • UTENSILI DIAMANTATI



UTENSILI DIAMANTATI "DNA"
"DNA" DIAMOND TOOLS
OUTILS DIAMANT "DNA"
"DNA" DIAMANT-WERKZEUGE

pag. 48



DISCHI DIAMANTATI
DIAMOND BLADES
DISQUES DIAMANTES
DIAMANTTRENNSCHEIBEN

pag. 60



FORATURA
DRILLING
PERÇAGE
BOHREN

pag. 67



LEVIGATURA
GRINDING
PONÇAGE
SCHLEIFEN

pag. 76



ESPOSITORI MODULARI
ASSEMBLING DISPLAYS
PRÉSENTOIRS MODULAIRES
AUSTELL-MODULE

pag. 80

COVER



PAG. 6

MOTO FLASH LINE



PAG. 19

BANCO DA LAVORO WORKING TABLE



PAG. 21

SUPERPROFILE



PAG. 23

F1 BROOKLYN



PAG. 27

X-WORKS



PAG. 43

DNA CONTINUOUS RIM



PAG. 50

DNA CONTINUOUS RIM



PAG. 51

SINTERIZED FOR GLASS



PAG. 74

Descrizioni ed illustrazioni si intendono fornite a semplice titolo indicativo. La Casa si riserva il diritto, ferme restando le caratteristiche essenziali dei modelli qui descritti ed illustrati, di apportare ai propri prodotti, in qualunque momento, e senza preavviso, le eventuali modifiche da essa ritenute necessarie a scopo di miglioramento o per qualsiasi esigenza di carattere costruttivo o commerciale.





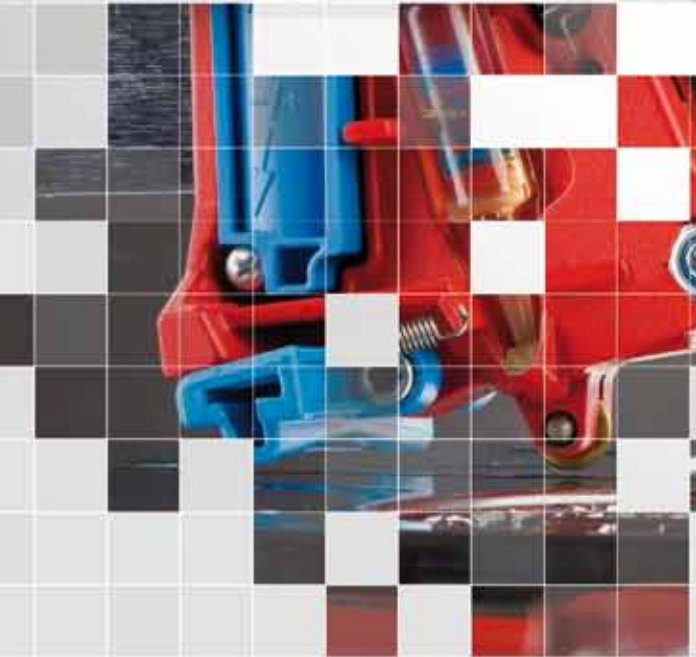

Descriptions and illustrations are purely indicative. Without prejudice to the essential features of the models described and illustrated herein, the Company reserves all rights of marking product changes and without notice at any moment considered necessary for improvement of required in the interest of product engineering and sale.

Toutes les descriptions et illustrations sont fournies à titre indicatif. Etant entendues les données essentielles des modèles ci décrits et illustrés, la Société se réserve le droit de modifier les produits toutes les fois et sans préavis au but de leur amélioration ou du point de vue constructif et de la commercialisation.

Abbildungen und Beschreibungen sind nicht verbindlich. Die Firma MONTOLIT behält sich das Recht vor, zu jeder Zeit und ohne Voranmeldung Änderungen, und Besserungen der Produkte vorzunehmen, sowohl in technischer als auch in kaufmännischer Hinsicht.



RICAMBI • SPARE PARTS
PIECES DETACHEES • ERSATZTEILE

Art.			€
	ROTELLA INCISION WHEEL MOLETTE RÄDCHEN		
245		B/12	5,00
245T	"TITANIUM"	B/12	7,00
	PORTAROTELLE INCISION HANDLE PORTE MOLETTE RÄDCHENHALTER		
505	7mm Con rotella "TITANIUM"	S/1	62,00
506	12mm Con rotella "TITANIUM"	S/1	66,00
	SEPARATORI SPLITTERS SEPARATEURS BRECHVORRICHTUNG		
507	Troncatore x artt. 505 - 506 (serie P3)	B/1	16,00
446P	Troncatore e piedini x artt. 445P - 445P12 (serie P2)	B/1	12,00
318	10 pcs piedini x artt. 445P - 445P12 (serie P2)	B/1	6,00
	LUBRIFICANTE LUBRICANT LUBRIFIANT SCHMIERSTOFF		
515-5	Set 5 pcs	V/1	6,00
	NASELLO MEASUREMENT SQUARE MENTONNET NASE		
428P2	x serie P2/P3	V/1	18,00
	COPPIA RIGHETTE MEASUREMENT GUIDE STICKERS COUPLE DE REGLES PAAR VON MASSTAE BEN		
480P2	x artt. 44-52 P2/P3	V/1	12,00
481P2	x artt. 63-75-93-125-155 P2/P3	V/1	14,00
	SQUADRA MEASUREMENT GUIDE EQUERRE WINKEL		
455P2	x artt. 44-52 P2/P3	V/1	74,00
456P2	x artt. 63-75-93 P2/P3	V/1	76,00
457P2	x artt. 125-155 P2/P3	V/1	78,00
*459P	Prolunga x serie P2/P3	V/1	19,00
	COPPIA LAMIERE METAL SUPPORT TABLES TOLES PAAR STAHLBLECHE		
418P	Complete di molle e perni	S/1	25,00
	GOMMINI RUBBER FEETS PIEDS STÜTZEN		
281	Set 5 pcs	B/1	9,00
	CONFEZIONE MINUTERIA ASSORTED PIECES PIECES ASSORTIES GEMISCHTER SATZ		
440P2	x serie P2/P3	S/1	22,00

OPTIONAL

• MOSAKIT

TAPPETINO IN GOMMA PER MOSAICI,
PIASTRELLE IN VETRO, DELICATE E SOTTILI (3MM).

RUBBER PAD FOR MOSAIC TILES, PLUS
DELICATE AND VERY THIN 3MM GLASS TILES.

TAPIS EN CAOUTCHOUC POUR CARREAUX DE MOSAÏQUE,
DU VERRE ET DU CARRELAGE FIN ET DÉLICAT (3MM).

GUMMI-MATTE FÜR MOSAIKFLIESEN, GLAS,
ZERBRECHLICHEN UND DÜNNEN FLIESEN (3MM).



Art. 58

€ 42,00

OPTIONAL

• BASEBOARD

RIFERIMENTO AGGIUNTIVO PER GRANDI FORMATI IDEALE
PER IL TAGLIO DI LISTELLI E DI BATTISCOPA.

BRACKET PRECISION FOR CUTTING STRIP TILES
AND SKIRTING BOARDS.

RÉFÉRENCE SUPPLÉMENTAIRE POUR LES GRANDES
TAILLES IDÉAL POUR COUPER BANDES ET PLINTHES.

ZUSÄTZLICHER BEZUGSPUNKT FÜR GROSSE FORMATE,
IDEAL ZUM ZUSCHNEIDEN VON SOCKELLEISTEN.



Art. 64

€ 46,00

OPTIONAL

• PIEDONE

SISTEMA DI SPACCO SUPPLEMENTARE PER PIASTRELLE DI
GRANDI DIMENSIONI (FINO A 155 CM) E GRES PORCELLANATO
SPESSORATO (MAX 2 CM).

ADDITIONAL SPLITTING SYSTEM FOR EXTRA LARGE TILES SIZE
(UP TO 155CM) AND PORCELAIN TILE THICKNESS (MAX 2 CM).

SYSTÈME DE FISSURATION SUPPLÉMENTAIRE POUR CARREAUX
DE GRANDE TAILLE (JUSQU'À 155 CM) ET LES CARREAUX DE
PORCELAINE CALÉS (MAX 2 CM).

ZUSÄTZLICHES TRENNSYSTEM FÜR GROSSE FLIESEN (BIS
155 CM) UND VERSTÄRKTEM FEINSTEINZEUG (MAX. 2 CM).



Art. 449P

€ 28,00

OPTIONAL

• VERTIGO 2

SUPPORTO PER TAGLIAPIASTRELLE MANUALI
(ARTT.125 E 155 P2/P3), AGEVOLA IL TAGLIO IN
VERTICALE DELLE PIASTRELLE DI GRANDE FORMATO

SUPPORT FOR MANUAL TILE CUTTER
(ARTT.125 AND 155 P2/P3), FACILITATES THE
VERTICAL CUTTING OF LARGE FORMAT TILES.

SUPPORT POUR DECOUPEUSE MANUELLE
(ARTT.125 ET 155 P2/P3), FACILITE LA COUPE
VERTICALE DE CARREAUX DE GRAND FORMAT.

UNTERSTÜTZUNG FÜR MANUELLE FLIESENSCHNEIDER
(ART.125 UND 155 P2/P3), ERLEICHTERT DIE VERTIKALEN
SCHNEIDEN VON GROSSFORMATIGE FLIESEN.



Art. VERTIGO2

€ 288,00

OPTIONAL

• COVER

PROTEZIONE
PER TAGLIAPIASTRELLE

PROTECTION
FOR TILE CUTTERS

PROTECTION POUR
DECOUPEUSE À CARREAUX

SCHUTZ FÜR
FLIESENSCHNEIDER



Art. COVER

€ 40,00

MASTERPIUMA EVOLUTION 3

TAGLIAPIASTRELLE • TILE CUTTERS • DÉCOUPEUSE À CARREAUX • FLIESENSCHNEIDER

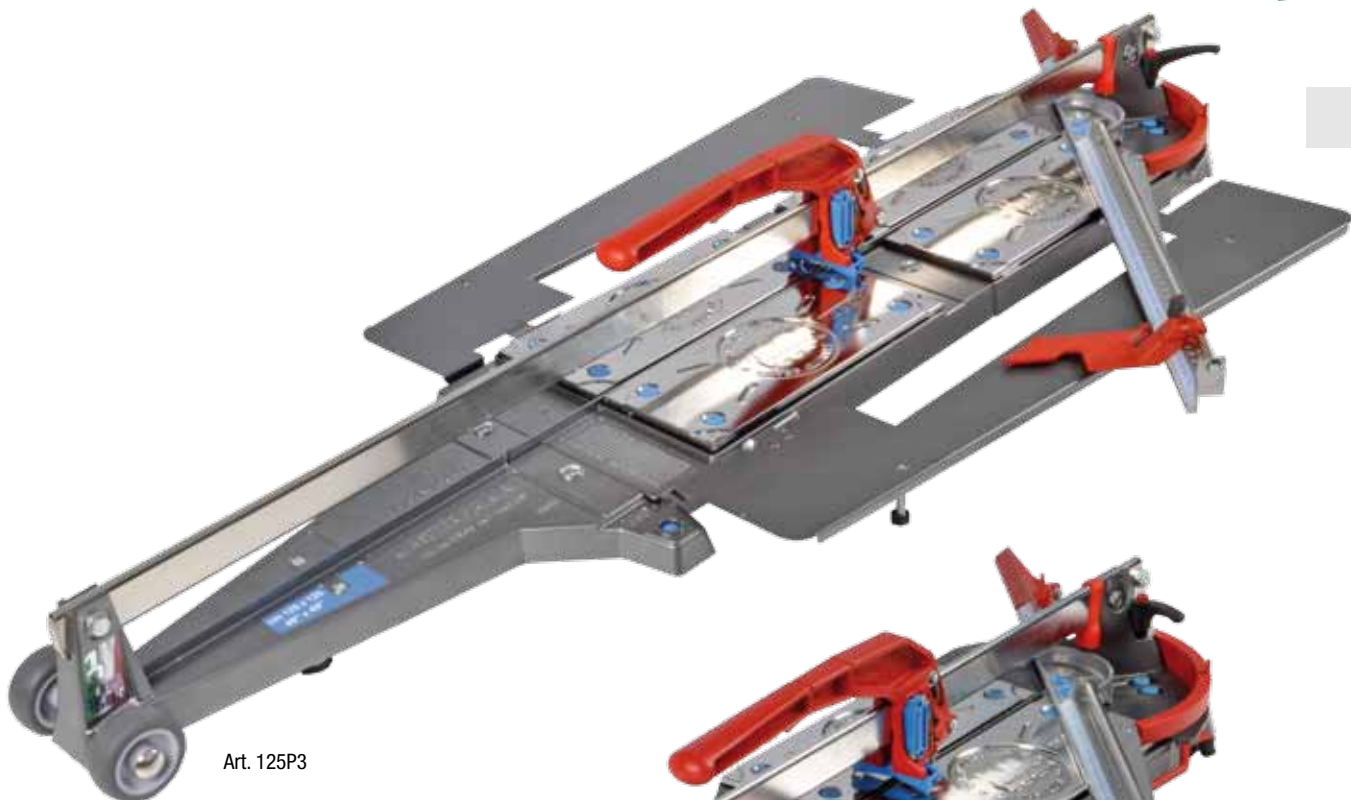

Art. 125P3

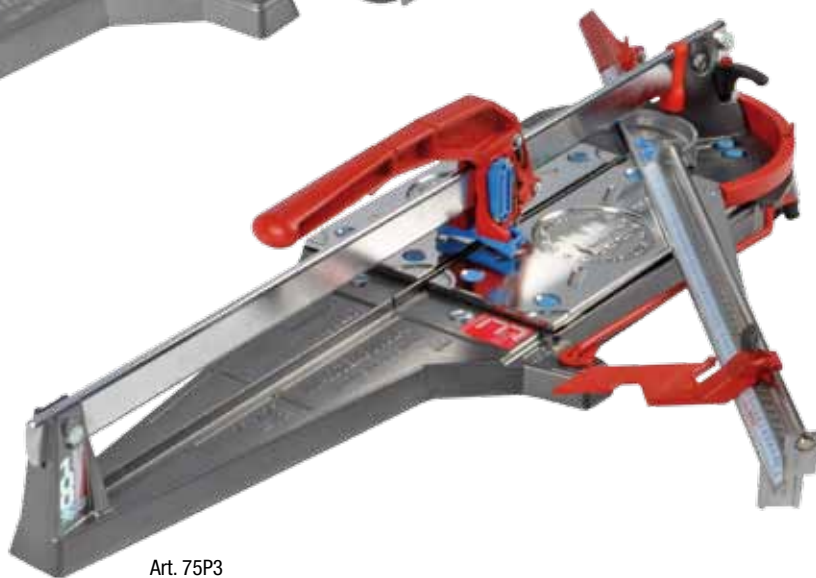

Art. 75P3

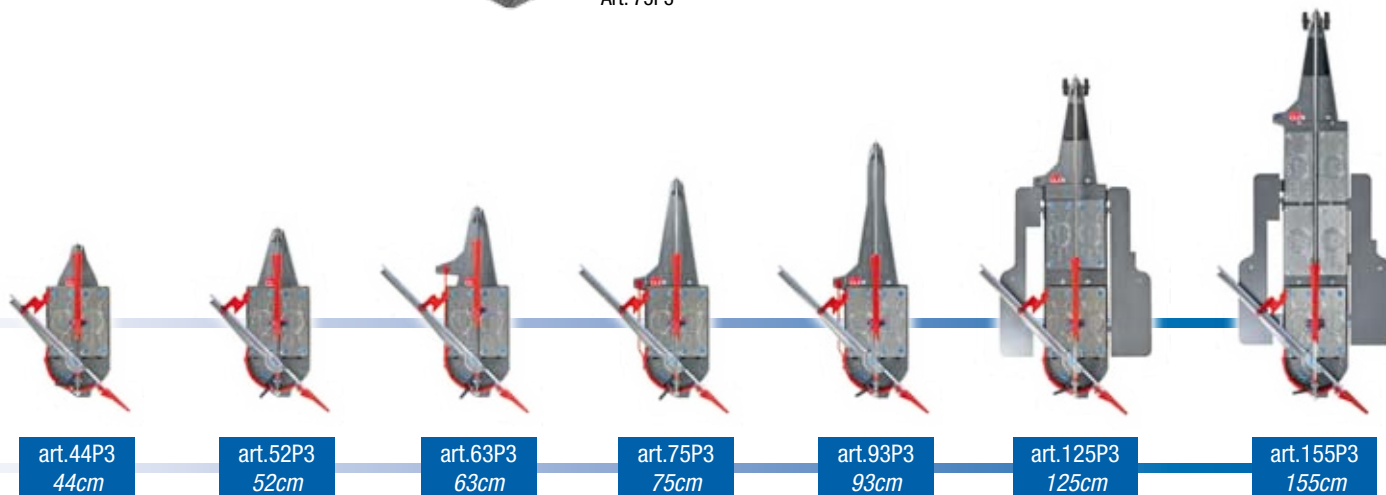

art.44P3
44cm

art.52P3
52cm

art.63P3
63cm

art.75P3
75cm

art.93P3
93cm

art.125P3
125cm

art.155P3
155cm

Art.									€
	cm	inch	cm	inch	cm	inch			
44P3	44	17	31 x 31	12 x 12	0 ÷ 2,2	0 ÷ 7/8	7,7	C/1	214,00
52P3	52	20	37 x 37	14 x 14	0 ÷ 2,2	0 ÷ 7/8	8,2	C/1	236,00
63P3	63	25	44 x 44	17 x 17	0 ÷ 2,2	0 ÷ 7/8	9,5	C/1	262,00
75P3	75	29	53 x 53	21 x 21	0 ÷ 2,2	0 ÷ 7/8	11,8	C/1	312,00
93P3	93	36	66 x 66	26 x 26	0 ÷ 2,2	0 ÷ 7/8	13,0	C/1	356,00
125P3	125	49	88 x 88	34,5 x 34,5	0 ÷ 2,2	0 ÷ 7/8	24,0	C/1	598,00
155P3	155	61	109 x 109	43 x 43	0 ÷ 2,2	0 ÷ 7/8	33,0	C/1	764,00

RICAMBI • SPARE PARTS				PIECES DETACHEES • ERSATZTEILE			
Art.		€	Art.		€		
			ROTELLA INCISION WHEEL MOLETTE RÄDCHEN				
245		B/12	5,00				
245T	"TITANIUM"	B/12	7,00	SQUADRA MEASUREMENT GUIDE EQUERRE WINKEL			
			PORTAROTELLE INCISION HANDLE PORTE MOLETTE RÄDCHENHALTER				
445BP	x artt. 63BP-75BP-93BP	S/1	39,00				
445BP12	x artt. 125BP	S/1	42,00	NASELLO MEASUREMENT SQUARE MENTONNET NASE			
			SEPARATORI SPLITTERS SEPARATEURS BRECHVORRICHTUNG				
446P	Troncatore e piedini	B/1	12,00	428T	V/1		
318	Piedini (10pcs)	B/1	6,00		14,00		
			COPPIA LAMIERE METAL SUPPORT TABLES TOLES PAAR STAHLBLECHE				
460P			V/1	COPPIA RIGHETTE MEASUREMENT GUIDE STICKERS COUPLE DE REGLES PAAR VON MASSTAEBen			
418P	Complete di molle e perni	S/1	25,00	460P	V/1		
			CONFEZIONE MINUTERIA ASSORTED PIECES PIECES ASSORTIES GEMISCHTER SATZ				
440P		V/1	18,00				
				GOMMINI RUBBER FEETS PIEDS STÜTZEN			
			281	Set 5 pcs	B/1		
					9,00		

OPTIONAL

- **MOSAKIT**
TAPPETINO IN GOMMA
RUBBER PAD
TAPIS EN CAOUTCHOUC
GUMMI-MATTE

Art. 58
€ 42,00



OPTIONAL

- **BASEBOARD**
RIFERIMENTO AGGIUNTIVO
PER GRANDI FORMATI.
BRACKET PRECISION FOR
BIG FORMAT.
RÉFÉRENCE SUPPLÉMENTAIRE
POUR LES GRANDES TAILLES.
ZUSÄTZLICHER BEZUGSPUNKT
FÜR GROSSE FORMATE.

Art. 64
€ 46,00



RICAMBI • SPARE PARTS				PIECES DETACHEES • ERSATZTEILE			
Art.		€	Art.		€		
			ROTELLA INCISION WHEEL MOLETTE RÄDCHEN				
245		B/12	5,00				
245T	"TITANIUM"	B/12	7,00	NASELLO MEASUREMENT SQUARE MENTONNET NASE			
			PORTAROTELLE INCISION HANDLE PORTE MOLETTE RÄDCHENHALTER				
447T	Con rotella "TITANIUM"	S/1	39,00				
			SEPARATORI SPLITTERS SEPARATEURS BRECHVORRICHTUNG				
318	Piedini x artt. 44T (10pcs)	B/1	6,00	COPPIA RIGHETTE MEASUREMENT GUIDE STICKERS COUPLE DE REGLES PAAR VON MASSTAEBen			
			COPPIA LAMIERE METAL SUPPORT TABLES TOLES PAAR STAHLBLECHE				
418P	Complete di molle e perni	S/1	25,00				
			CONFEZIONE MINUTERIA ASSORTED PIECES PIECES ASSORTIES GEMISCHTER SATZ				
			SQUADRA MEASUREMENT GUIDE EQUERRE WINKEL				
455T2	x artt. 44T2-52T2	V/1	70,00	281	Set 5 pcs		
456T2	x artt. 63T2-75T2-93T2	V/1	76,00		9,00		
*459P	Prolunga x serie T2	V/1	19,00				
454T	x artt. 63T	V/1	62,00	CONFEZIONE MINUTERIA ASSORTED PIECES PIECES ASSORTIES GEMISCHTER SATZ			
455T	x artt. 44T-52T	V/1	60,00	440P2	x serie T2		
456T	x artt. 75T-93T	V/1	64,00	440P	x serie T		
					S/1		
					22,00		
					S/1		
					18,00		

OPTIONAL

- **MOSAKIT**
TAPPETINO IN GOMMA
RUBBER PAD
TAPIS EN CAOUTCHOUC
GUMMI-MATTE

Art. 58
€ 42,00





OPTIONAL

- **BASEBOARD**
RIFERIMENTO AGGIUNTIVO
PER GRANDI FORMATI.
BRACKET PRECISION FOR
BIG FORMAT.
RÉFÉRENCE SUPPLÉMENTAIRE
POUR LES GRANDES TAILLES.
ZUSÄTZLICHER BEZUGSPUNKT
FÜR GROSSE FORMATE.

Art. 64
€ 46,00



 * Condizioni particolari: contattare Agente di zona e/o ufficio vendite Brevetti MONTOLIT.

 * Please call Brevetti MONTOLIT sales department for special sales conditions.

 * Conditions spéciales: veuillez contacter le service commercial de la Brevetti MONTOLIT.





 * Für Sonderkonditionen (z.B. Mengenrabatte) wenden Sie sich bitte an das Verkaufsbüro der Firma Brevetti MONTOLIT.

PIUMA BASIC

TAGLIAPIASTRELLE • TILE CUTTERS • DÉCOUPEUSE À CARREAUX • FLIESENSCHNEIDER



Art. 63BP





Art.							kg		€
	cm	inch	cm	inch	cm	inch			
63BP	63	25	44 x 44	17 x 17	0 ÷ 2,2	0 ÷ 7/8	8	C/1	*
75BP	75	29	53 x 53	21 x 21	0 ÷ 2,2	0 ÷ 7/8	9	C/1	*
93BP	93	36	66 x 66	26 x 26	0 ÷ 2,2	0 ÷ 7/8	10	C/1	*
125BP	125	49	88 x 88	34,5 x 34,5	0 ÷ 2,2	0 ÷ 7/8	20	C/1	*
NEW 155BP	155	61	109 x 109	43 x 43	0 ÷ 2,2	0 ÷ 7/8	27,5	C/1	*

MASTERPIUMA 2

TAGLIAPIASTRELLE • TILE CUTTERS • DÉCOUPEUSE À CARREAUX • FLIESENSCHNEIDER



Art. 52T2

Art.							kg		€
	cm	inch	cm	inch	cm	inch			
44T2	44	17	31 x 31	12 x 12	0 ÷ 2	0 ÷ 3/4	7,7	C/1	202,00
52T2	52	20	37 x 37	14 x 14	0 ÷ 2	0 ÷ 3/4	8,0	C/1	214,00
63T2	63	25	44 x 44	17 x 17	0 ÷ 2	0 ÷ 3/4	9,1	C/1	240,00
75T2	75	29	53 x 53	21 x 21	0 ÷ 2	0 ÷ 3/4	10,2	C/1	284,00
93T2	93	36	66 x 66	26 x 26	0 ÷ 2	0 ÷ 3/4	11,3	C/1	324,00

RICAMBI • SPARE PARTS				PIECES DETACHEES • ERSATZTEILE			
Art.		€	Art.		€		
							
245		B/12	5,00	429P	B/1	20,00	
245T	"TITANIUM"	B/12	7,00				
							
264P		S/1	39,00	458P	V/1	8,00	
							
448P		B/1	9,00	280P	Complete di molle e perni	S/1	22,00
							
452P		V/1	44,00	277P	Set 5 pcs	B/1	8,00

OPTIONAL

• MOSAKIT

TAPPETINO IN GOMMA PER MOSAICI, PIASTRELLE IN VETRO, DELICATE E SOTTILI (3MM).

RUBBER PAD FOR MOSAIC TILES, PLUS DELICATE AND VERY THIN 3MM GLASS TILES.

TAPIS EN CAOUTCHOUC POUR CARREAUX DE MOSAÏQUE, DU VERRE ET DU CARRELAGE FIN ET DELICAT (3MM).

GUMMI-MATTE FÜR MOSAIKFLIESEN, GLAS, ZERBRECHLICHEN UND DÜNNEN FLIESEN (3MM).



Art. 58

€ 42,00



RICAMBI • SPARE PARTS				PIECES DETACHEES • ERSATZTEILE			
Art.		€	Art.		€		
							
245		B/12	5,00	429P	B/1	20,00	
245T	"TITANIUM"	B/12	7,00				
							
264T		S/1	39,00	458T	V/1	8,00	
							
318	Set 10 pcs	B/1	6,00	280P	Complete di molle e perni	S/1	22,00
							
452T		V/1	44,00	277P	Set 5 pcs	B/1	8,00

OPTIONAL

• MOSAKIT

TAPPETINO IN GOMMA PER MOSAICI, PIASTRELLE IN VETRO, DELICATE E SOTTILI (3MM).

RUBBER PAD FOR MOSAIC TILES, PLUS DELICATE AND VERY THIN 3MM GLASS TILES.

TAPIS EN CAOUTCHOUC POUR CARREAUX DE MOSAÏQUE, DU VERRE ET DU CARRELAGE FIN ET DELICAT (3MM).

GUMMI-MATTE FÜR MOSAIKFLIESEN, GLAS, ZERBRECHLICHEN UND DÜNNEN FLIESEN (3MM).



Art. 58

€ 42,00



MINIPIUMA

TAGLIAPIASTRELLE • TILE CUTTERS • DÉCOUPEUSE À CARREAUX • FLIESENSCHNEIDER



Art. 26PB

Art.									€
	cm	inch	cm	inch	cm	inch			
26P	36	14	25 x 25	10 x 10	0 ÷ 2	0 ÷ 3/4	3,2	C/1	134,00
26PBox	36	14	25 x 25	10 x 10	0 ÷ 2	0 ÷ 3/4	5,8	C/2	161,00
43P	45	18	31 x 31	12 x 12	0 ÷ 2	0 ÷ 3/4	3,7	C/1	159,00
43PBox	45	18	31 x 31	12 x 12	0 ÷ 2	0 ÷ 3/4	6,3	C/2	188,00

MINIPIUMA

TAGLIAPIASTRELLE • TILE CUTTERS • DÉCOUPEUSE À CARREAUX • FLIESENSCHNEIDER



Art. 26TB





Art.									€
	cm	inch	cm	inch	cm	inch			
26T	36	14	25 x 25	10 x 10	0 ÷ 2	0 ÷ 3/4	3,2	C/1	128,00
26TBox	36	14	25 x 25	10 x 10	0 ÷ 2	0 ÷ 3/4	5,8	C/2	158,00
43T	45	18	31 x 31	12 x 12	0 ÷ 2	0 ÷ 3/4	3,7	C/1	156,00
43TBox	45	18	31 x 31	12 x 12	0 ÷ 2	0 ÷ 3/4	6,3	C/2	185,00

RICAMBI • SPARE PARTS
PIECES DETACHEES • ERSATZTEILE

Art.			€
	ROTELLA INCISION WHEEL MOLETTE RÄDCHEN		
245		B/12	5,00
245T	"TITANIUM"	B/12	7,00
	PORTAROTELLE INCISION HANDLE PORTE MOLETTE RÄDCHENHALTER		
259	x art. 24	B/1	17,00
264	x artt. 26-26A-43-43A	S/1	26,00
264B	x artt. 26A2-43A2	S/1	27,00
	SEPARATORI SPLITTERS SEPARATEURS BRECHVORRICHTUNG		
318	Set 10 pcs x artt. 264-264B	B/1	6,00
	COPPIA LAMIERE METAL SUPPORT TABLES TOLES PAAR STAHLBLECHE		
280	x artt. 26A-26A2-43A-43A2	S/1	18,00
	GOMMINI RUBBER FEETS PIEDS STÜTZEN		
277	Set 5 pcs	B/1	5,00



RICAMBI • SPARE PARTS
PIECES DETACHEES • ERSATZTEILE

Art.			€
	ROTELLA INCISION WHEEL MOLETTE RÄDCHEN		
242TS	"TITANIUM"	B/1	19,00
	RIGHETTE MEASUREMENT GUIDE STICKERS REGLES MASSTAEBEN		
284S	x art. S51	V/1	11,00
285S	x art. S63	V/1	18,00
	SQUADRA MEASUREMENT GUIDE EQUERRE WINKEL		
280S		V/1	39,00
	GOMMINI RUBBER FEETS PIEDS STÜTZEN		
279		V/1	4,00

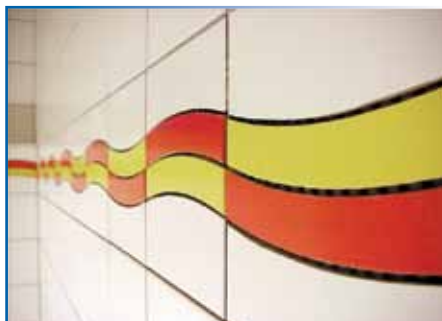

OPTIONAL

- RADIUS 300 ÷ 3000mm

DIMA VARIABILE
 VARIABLE TEMPLATE
 GABARIT VARIABLE
 SCHABLONE MULTIRADIUS



Art. SR000B

€ 198,00



MINIMONTOLIT 2

TAGLIAPIASTRELLE • TILE CUTTERS • DÉCOUPEUSE À CARREAUX • FLIESENSCHNEIDER



Art. 26A2

Art.							kg	BOX	€
	cm	inch	cm	inch	cm	inch			
24	22	8	15 x 15	6 x 6	0 ÷ 1,5	0 ÷ 1/2	0,6	C/6	38,00
26A2	36	14	25 x 25	10 x 10	0 ÷ 2	0 ÷ 3/4	2,8	C/6	72,00
43A2	45	18	31 x 31	12 x 12	0 ÷ 2	0 ÷ 3/4	3,5	C/2	104,00

COMBI SLALOM

TAGLIAPIASTRELLE PER TAGLI DRITTI E CURVILINEI • TILE CUTTER FOR STRAIGHT CUTS AND CURVED
 DÉCOUPEUSE À CARREAUX POUR LES COUPES DROITES ET COURBES • FLIESENSCHNEIDER FÜR GERADE SCHNITTE UND GEKRÜMMTE



Art.							kg	BOX	€
	cm	inch	cm	inch	cm	inch			
S63	63	24	44 x 44	17 x 17	0 ÷ 2	0 ÷ 3/4	19	C/1	488,00

RICAMBI • SPARE PARTS • PIECES DETACHEES • ERSATZTEILE

Art.			€	Art.			€	Art.			€
	ROTELLA INCISION WHEEL MOLETTE RÄDCHEN				LAMIERA METAL SUPPORT TABLE TOLE BLEC				SQUADRA MEASUREMENT GUIDE EQUERRE WINKEL		
240	x artt. 21-22-25-27-28-29	B/12	4,50	310	x artt. 29-31	V/1	18,00	252D	x art. 46	V/1	52,00
241	x MASTERMONTOLIT	B/12	5,00	312	x art. 34	V/1	21,00	253D	x art. 31	V/1	44,00
241T	"TITANIUM" x MASTERMONTOLIT	B/12	7,00	313M	x artt. 47M-92-121	V/1	35,00	254D	x art. 34	V/1	48,00
	art. 392 PORTAROTELLE INCISION HANDLE PORTE MOLETTE RÄDCHENHALTER			314	x art. 46	V/1	23,00	257D	x artt. 47-49-92V	V/1	72,00
261	x art. 31	S/1	26,00	316	x art. 92V	V/1	48,00	257M	x art. 47M-92	V/1	52,00
261R	In acciaio x art. 31	S/1	34,00		art. 290T COPPIA PATELLE TILE CLAMPS PATELLES PLAETTCHEN				NASELLO MEASUREMENT SQUARE MENTONNET NASE		
262R	In acciaio x artt. 34-46-47	S/1	37,00	331	x art. 31	V/1	16,00	326	x artt. 31-34-46	V/1	14,00
392	Speciale x artt. 34-46-47M-92-121	S/1	53,00	332	x art. 34	V/1	24,00	327	x artt. 47-47M-49-92-121	V/1	16,00
390	Prolunga x art. 392	V/1	22,00	333	x artt. 47M-92-121	V/1	29,00		CONFEZIONE MINUTERIA ASSORTED PIECES PIECES ASSORTIES GEMISCHTER SATZ		
				334	x art. 46	V/1	28,00	370		S/1	44,00
								281	Gommini - set 5 pcs	B/1	9,00

RICAMBI • SPARE PARTS • PIECES DETACHEES • ERSATZTEILE

Art.			€	Art.			€
	ROTELLA INCISION WHEEL MOLETTE RÄDCHEN				art. 255 SQUADRA MEASUREMENT GUIDE EQUERRE WINKEL		
242		B/1	9,50	255	x artt. 36-36S	V/1	28,00
242T	"TITANIUM"	B/1	12,00	256	x artt. 38-38S-41-41S-44	V/1	32,00
				290T	Squadra goniometrica	V/1	33,00
	PORTAROTELLE INCISION HANDLE PORTE MOLETTE RÄDCHENHALTER				GOMMINI RUBBER FEETS PIEDS STÜTZEN		
263	x artt. 36-38-41-44-48	B/1	36,00	279		V/1	4,00
263S	x artt. 36S-38S-41S	B/1	34,00				

OPTIONAL

TENAGLIA PER PIASTRELLE/MOSAICO
TILES/MOSAIC NIBBLER
TENAILLE POUR CARREAUX/MOSAIQUE
ZANGE FÜR FLIESEN/MOSAİK

Art. 40

€ 64,00



RICAMBI • SPARE PARTS • PIECES DETACHEES • ERSATZTEILE

Art.			€	Art.			€
	ROTELLA COMPLETA COMPLETE INCISION WHEEL MOLETTE COMPLETE RÄDCHEN KOMPLETT				COPPIA LAMIERE METAL SUPPORT TABLES TOLES PAAR STAHLBLECHE		
SL01		B/1	6,00	SL04		V/1	18,00
	PORTAROTELLE INCISION HANDLE PORTE MOLETTE RÄDCHENHALTER				ESTENSIONE SQUADRA EXTENSION FOR SQUARE PROLONGATEUR DE L'EQUERRE VERLÄNGERUNG FÜR WINKEL		
SL02		S/1	23,00	SL05	x art. SL43	V/1	10,00
				SL06	x art. SL53 - SL63	V/1	12,00
	SEPARATORE SPLITTER SEPARATEUR BRECHVORRICHTUNG				NASELLO MEASUREMENT SQUARE MENTONNET NASE		
SL03		B/1	6,00	SL07		V/1	16,00

OPTIONAL

• MOSAKIT

TAPPETINO IN GOMMA PER MOSAICI, PIASTRELLE
IN VETRO, DELICATE E SOTTILI (3MM).

RUBBER PAD FOR MOSAIC TILES, PLUS DELICATE
AND VERY THIN 3MM GLASS TILES.

TAPIS EN CAOUTCHOUC POUR CARREAUX DE MOSAÏQUE,
DU VERRE ET DU CARRELAGE FIN ET DÉLICAT (3MM).

GUMMI-MATTE FÜR MOSAIKFLIESEN, GLAS,
ZERBRECHLICHEN UND DÜNNEN FLIESEN (3MM).

Art. 58

€ 42,00

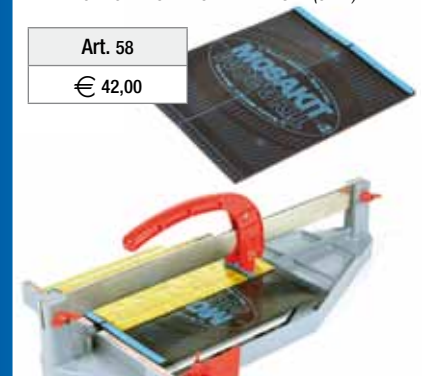





MASTERMONTOLIT

TAGLIAPIASTRELLE • TILE CUTTERS • DÉCOUPEUSE À CARREAUX • FLIESENSCHNEIDER







Art. 47M

Art.									€
	cm	inch	cm	inch	cm	inch	kg	BOX	
46	50	20	35 x 35	14 x 14	0 ÷ 2,5	0 ÷ 1	15,5	C/1	312,00
47M	62	24	44 x 44	17 x 17	0 ÷ 2,5	0 ÷ 1	16,5	C/1	388,00

TAGLIAPIASTRELLE / MOSAICO • CERAMIC / MOSAIC TILE CUTTERS
DÉCOUPEUSE À CARREAUX / MOSAÏQUE • IDEAL-MOSAÏK UND FLIESENSCHNEIDER



Art. 36S





Art.									€
	cm	inch	cm	inch	cm	inch	kg	BOX	
36S	37	14	26 x 26	10 x 10	0 ÷ 2	0 ÷ 3/4	7,4	C/1	182,00
38S	53	21	37 x 37	14 x 14	0 ÷ 2	0 ÷ 3/4	8,8	C/1	194,00

SMART LINE

TAGLIAPIASTRELLE • TILE CUTTERS • DÉCOUPEUSE À CARREAUX • FLIESENSCHNEIDER



Art. SL53

Art.									€
	cm	inch	cm	inch	cm	inch	kg	BOX	
SL33	33	13	24 x 24	9 x 9	0 ÷ 2,2	0 ÷ 7/8	4,7	C/1	148,00
SL43	43	17	31 x 31	12 x 12	0 ÷ 2,2	0 ÷ 7/8	5,4	C/1	156,00
SL53	53	21	38 x 38	15 x 15	0 ÷ 2,2	0 ÷ 7/8	6,3	C/1	168,00
SL63	63	24	45 x 45	18 x 18	0 ÷ 2,2	0 ÷ 7/8	6,5	C/1	174,00

LIFTILE

SISTEMA DI SOLLEVAMENTO E MOVIMENTAZIONE DI LASTRE SU RUOTE

WHEELED SYSTEM FOR LIFTING AND HANDLING SLABS

SYSTEME DE LEVAGE ET TRAITEMENT DES GRANDS CARREAUX SUR ROUES

FAHRBARES HEBE- UND HANDLING-SYSTEM FÜR GROSSFORMATIGE FLIESEN

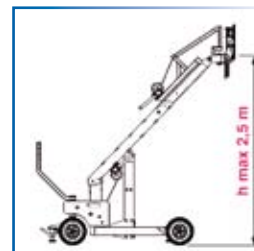

**NEW
2017**

Condizioni particolari: contattare Agente di zona e/o ufficio vendite Brevetti MONTOLIT.

Please call Brevetti MONTOLIT sales department for special sales conditions.

Conditions spéciales: veuillez contacter le service commercial de la Brevetti MONTOLIT.

Für Sonderkonditionen (zB. Mengenrabatte) wenden Sie sich bitte an das Verkaufsbüro der Firma Brevetti MONTOLIT.

GOAL

CARRELLO POLIFUNZIONALE PER IL TRASPORTO E LA LAVORAZIONE DI LASTRE

MULTI-PURPOSE BOGIE FOR THE TRANSPORT AND PROCESSING OF SLABS

CHARIOT MULTI-USAGE POUR LE TRANSPORT ET TRAITEMENT DES GRANDS CARREAUX

MEHRZWECK DREHGESTELL FÜR DIE TRANSPORT UND VERARBEITUNG VON GROSSEN FLIESEN



Art.			€
300-85	kg 20	C/1	408,00

CORNER

PARASPIGOLI • CORNER PROTECTORS • PROTECTEURS D'ANGLE • KANTENSCHUTZ



Art. 300-95-10



Art.			€
300-95-04	mm 3 ÷ 4	inch 1/8 ÷ 5/32	Set 4 pcs. B/1 12,00
300-95-06	mm 5 ÷ 6	inch 3/16 ÷ 1/4	Set 4 pcs. B/1 14,00
300-95-10	mm 8 ÷ 10	inch 5/16 ÷ 3/8	Set 4 pcs. B/1 16,00
300-95-12	mm 11 ÷ 12	inch 7/16 ÷ 1/2	Set 4 pcs. B/1 18,00

**NEW
MODEL**

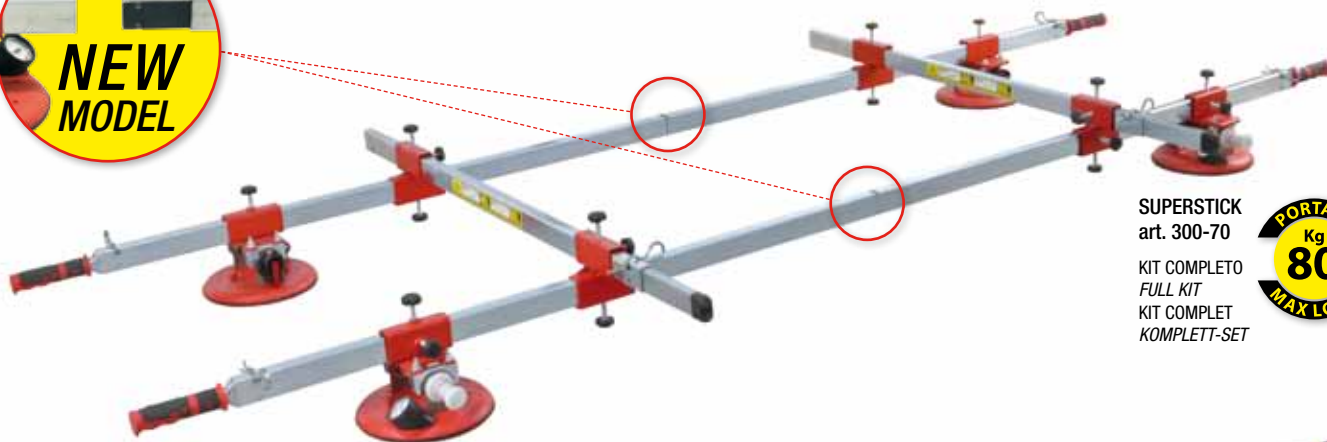

SUPERSTICK
 art. 300-70
 KIT COMPLETO
 FULL KIT
 KIT COMPLET
 KOMPLETT-SET



STICK
 art. 300-80
 KIT BASE
 BASIC KIT
 KIT DE BASE
 BASIC KIT

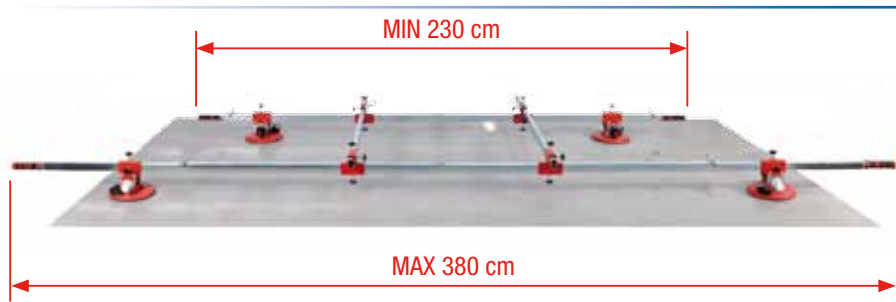

Art.	kg	BOX	€
300-80	9,5	C/1	468,00
300-70	30	C/1	1.068,00

OPTIONAL
 VENTOSA EXTRA
 EXTRA SUCTION CUP
 EXTRA VENTOUSE
 EXTRA SAUGNAPF

Art. 300-71 € 198,00

OPTIONAL
 CUFFIA PROTETTIVA PER VENTOSA
 PROTECTIVE CAP FOR SUCTION CUP
 CAPUCHON DE PROTECTION POUR VENTOUSE
 SCHUTZKAPPE FÜR SAUGNAPF

Art. 300-71P € 5,00

OPTIONAL
 SISTEMA DI SICUREZZA PER LASTRE CORRUGATE
 EXTRA SAFETY HOOKS FOR ROUGH SLABS
 CROCHETS DE SÉCURITÉ SUPPLÉMENTAIRES POUR LES CARREAUX RUGUEUSES
 SUPPORT FÜR STRUKTURIERTE OBERFLÄCHEN

Art. 300-77 € 196,00

FLASH LINE EVO

SISTEMA DI TAGLIO COMPLETO PER PIASTRELLE E LASTRE IN GRES PORCELLANATO DA 0 A 340 CM (134")

COMPLETE CUTTING SYSTEM FOR PORCELAIN TILES AND SLABS FROM 0 TO 340 CM (134")

SYSTÈME COMPLET DE COUPE POUR CARREAUX ET DALLES DE GRÈS CÉRAME 0-340 CM (134")

KOMPLETTES SCHNEIDSYSTEM FÜR FLIESEN UND PLATTEN AUS FEINSTEINZEUG-0-340 CM (134")

**NEW
2017**



ART. 400FL

ESPOSITORE

Condizioni particolari: contattare
Agente di zona e/o ufficio vendite
Brevetti MONTOLIT.

DISPLAY

Please call Brevetti MONTOLIT
sales department for special
sales conditions.

PRESENTOIRS

Conditions spéciales: veuillez
contacter le service commercial de la
Brevetti MONTOLIT.

DISPLAY

Für Sonderkonditionen (zB. Mengenrabatte) wenden
Sie sich bitte an das Verkaufsbüro der Firma Brevetti
MONTOLIT.



art. 56RJ
INCLUSO

IL KIT CONTIENE: n. 3 barre da 120cm - n.1 dispositivo di spacco (art. 56RJ) - n.1 carrello con rotella di incisione - n.1 sacca da trasporto

THE KIT CONTAINS: n. 3 120 cm (48") bars - n.1 incision splitting tool (art. 56RJ) - n.1 incision head/wheel - n.1 professional carrying bag

LE KIT CONTIENT: 3 profils de 120 cm - 1 dispositif de fissuration (art. 56RJ) - 1 chariot avec roulette d'incision - 1 sac pour le transport

IM SATZ ENTHALTEN SIND: 3 Profile à 120 cm - 1 Trennvorrichtung (art. 56RJ) - 1 Schlitten mit Schneidrad - 1 Tragtasche

Art.	cm		inch		kg	BOX	€
300-FL-EVO	340	134	0 ÷ 1	0 ÷ 3/8	8,0	C/1	398,00

RICAMBI • SPARE PARTS PIECES DETACHEES • ERSATZTEILE

Art.	BOX	€	Art.	BOX	€
240T	"TITANIUM"	B/1 6,00	300-FL-02	11 mt.	V/1 28,00
DOPPIO SISTEMA DI SPACCO DUAL SPLITTING SYSTEM DOUBLE SYSTÈME DE COUPE PARALLEL SYSTEM ZUM TRENNEN					
			300-FL-03		V/1 86,00
56RJ	max 15 mm	S/1 94,00	300-FL-01		B/1 38,00

OPTIONAL

PROLUNGA MODULARE
MODULAR EXTENSION
EXTENSION MODULAIRE
BAUKASTEN VERSLÄNGERUNG

Art. 300-FL-08

€ 112,00

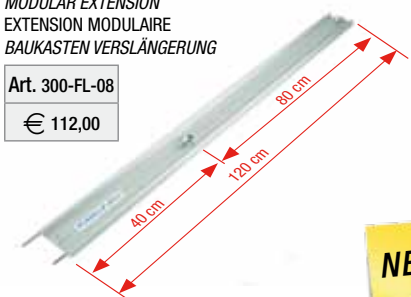

NEW

OPTIONAL

DOPPIO SISTEMA DI SPACCO RINFORZATO
REINFORCED DUAL SPLITTING SYSTEM
DOUBLE SYSTÈME DE COUPE RENFORCÉ
VERSTÄRKTES DOPPEL-BRECHSYSTEM

Art. 56R

(max 20 mm)

€ 124,00



NEW

SISTEMA MOTORIZZATO PER IL TAGLIO A SECCO DI PIASTRELLE E LASTRE IN GRES PORCELLANATO, GRANITO E MARMO DA 0 A 340 CM (134")

MOTORIZED SYSTEM FOR DRY CUTTING PORCELAIN, GRANITE AND MARBLE TILES AND SLABS FROM 0 TO 340 CM (134")

SYSTÈME MOTORISÉ POUR LA COUPE À SEC DE CARRELAGES ET DE DALLES EN GRÈS CÉRAME, GRANIT ET MARBRE DE 0 À 340 CM (134")

MOTORISIERTES SYSTEM ZUM TROCKENSCHNEIDEN VON FLIESEN UND PLATTEN AUS FEINSTEINZEUG, GRANIT UND MARMOR VON 0 BIS 340 CM (134")



**NEW
2017**

Art. **MOTO-300-FL**
3 x 120cm (4-3/4") + art. **MOTO-300-FL-PU**



Art. **MOTO-300-FL-PU**



Art.										€
		cm	inch	cm	inch	mm	inch			
MOTO-300-FL	230V~ · 1,6kW (2,1HP) · 50/60 Hz	340	134	0 ÷ 2	0 ÷ 3/4	150/30	6 / 1-3/16	12,8	C/1	€ 785,00
MOTO-300-FL-115V	110/120V~ · 1,6kW (2,1HP) · 50/60 Hz	340	134	0 ÷ 2	0 ÷ 3/4	150/30	6 / 1-3/16	12,8	C/1	€ 815,00
MOTO-300-FL-PU (Power Unit)	230V~ · 1,6kW (2,1HP) · 50/60 Hz	340	134	0 ÷ 2	0 ÷ 3/4	150/30	6 / 1-3/16	6,9	C/1	€ 595,00
MOTO-300-FL-PU-115V (Power Unit)	110/120V~ · 1,6kW (2,1HP) · 50/60 Hz	340	134	0 ÷ 2	0 ÷ 3/4	150/30	6 / 1-3/16	6,9	C/1	€ 625,00

DISCO DIAMANTATO INCLUSO:
DIAMOND BLADE INCLUDED:
DISQUE DIAMANTÉ INCLUSE:
DIAMANT-TRENNSCHEIBE ENTHALTEN:

art. **TCS150MFL**



Gres porcellanato alto spessore · Granito
Porcelain stoneware high thickness · Granite
Grès cérame à haute épaisseur · Granit
Feinsteinzeug hohe Dicke · Granit

OPTIONAL

Art. **TBH150**

€ 58,00

Lastre sottili in gres porcellanato
Porcelain stoneware slim slabs
Dalles de grès cérame mince
Feinsteinzeugplatten schlank

OPTIONAL

Art. **CS150MFL**

€ 66,00

CUT KIT

CUTTER PER VETRO/PIASTRELLE/LASTRE SOTTILI • CUTTER FOR GLASS/CERAMIC/LARGE FORMATS

CUTTER POUR VERRE/CERAMIQUE/CARREUX GRANDS FORMATS • MESSER FÜR GLASS/KERAMIK/GROSSE FORMATE



Art.		€
25V	B/1	24,00

VENTOSA PER GRANDI FORMATI • SUCTION CUP FOR BIG TILES

VENTOUSE POUR GRANDS CARREUX • SAUGNAPF FÜR GROSSE FLIESEN



Art.	∅ mm		€
300-76	200	C/1	148,00

NEW

NEW

OPTIONAL
SUPPORTO LATERALE (30CM)
LATERAL SUPPORT (30CM)
SUPPORT LATÉRAL (30CM)
SEITENHALT (30CM)



Art. 300-15EXT € 76,00



Art.	DIMENSIONI DIMENSIONS			€
	cm	kg	C/1	
300-15	180 x 90 x 83 (h)	31	C/1	574,00

2 x art. 300-15

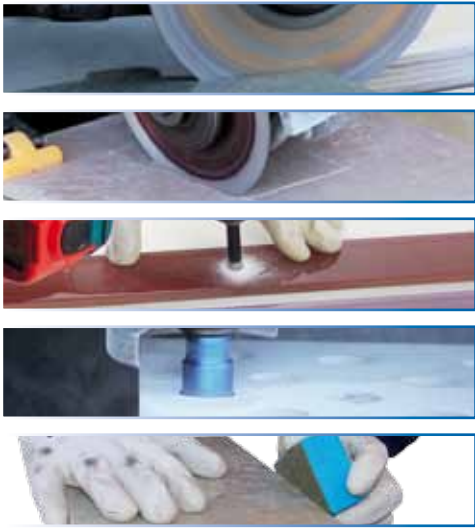

DIAMANT KIT

SET DIAMANTATO PER LASTRE • DIAMOND KIT FOR LARGE TILES
KIT DE DIAMANT POUR LES GRANDS FORMATS • DIAMANT-KIT FÜR GROSSE FORMATE



Art.			€
300-VA	Box + TCS85 + CTX115 + FAJ06/08 + FS27/35/50 + DT060 + DT200	C/1	498,00

SUPERPROFILE

PROFILATORE PROFESSIONALE • PROFESSIONAL BEVEL PROFILE

BISEAUTAGE PROFESSIONNELLE • PROFI-PROFILFRÄSE

	MOLA DIAMANTATA • DIAMOND TOOLS • FRAISE DIAMANTÉE • DIAMANT-FRÄSKOPF	Art.		€
15 mm 	FPE15SP	Grana media - Medium grain Grain moyen - Körnung mittel	B/1	158,00
	MOLA DIAMANTATA • DIAMOND TOOLS • FRAISE DIAMANTÉE • DIAMANT-FRÄSKOPF	Art.		€
15 mm 	FPE15SPGF	Grana fine - Fine grain Grain fin - Körnung fein	B/1	158,00
	MOLA DIAMANTATA • DIAMOND TOOLS • FRAISE DIAMANTÉE • DIAMANT-FRÄSKOPF	Art.		€
3 mm 	FPE03SP		B/1	118,00
	MOLA DIAMANTATA • DIAMOND TOOLS • FRAISE DIAMANTÉE • DIAMANT-FRÄSKOPF	Art.		€
5 mm 	FPE05SP		B/1	128,00
	MOLA DIAMANTATA • DIAMOND TOOLS • FRAISE DIAMANTÉE • DIAMANT-FRÄSKOPF	Art.		€
R 3 mm 	FPB03SP		B/1	118,00
	MOLA DIAMANTATA • DIAMOND TOOLS • FRAISE DIAMANTÉE • DIAMANT-FRÄSKOPF	Art.		€
R 5 mm 	FPB05SP		B/1	128,00
	MOLA DIAMANTATA • DIAMOND TOOLS • FRAISE DIAMANTÉE • DIAMANT-FRÄSKOPF	Art.		€
R 10 mm 	FPB10SP		B/1	146,00



ASPIRATORE PROFESSIONALE PER POLVERI E LIQUIDI • PROFESSIONAL VACUUM CLEANER FOR DUST AND LIQUIDS

ASPIRATEUR PROFESSIONNEL POUR POUDDRE ET LIQUIDE • PROFI-SAUGER FÜR STAUB UND FLÜSSIGKEIT



NEW



RICAMBI • SPARE PARTS PIECES DETACHEES • ERSATZTEILE				
Art.		€		
	ELEMENTO FILTRANTE A CARTUCCIA FILTER CARTRIDGE ÉLÉMENT FILTRANT À CARTOUCHE FILTERELEMENTKARTUSCHE			
MT-HOOV01		S/1	34,00	
	SACCHETTO RACCOGLIPOLVERE DUST COLLECTING BAG SAC COLLECTEUR DE POUSSIERE FILTERBEUTEL			
MT-HOOV02		S/1	38,00	

Art.		CAPACITÀ TANK CAPACITY	PORTATA ARIA MAX AIR FLOW MAX			€
		L	m³/h	kg		
MT-HOOV	230V~/1,2kW	50	166 (45 lt/sec)	11	C/1	380,00

SUPERPROFILE

PROFILATORE PROFESSIONALE • PROFESSIONAL BEVEL PROFILE

BISEAUTAGE PROFESSIONNELLE • PROFI-PROFILFRÄSE



NEW

SISTEMA BREVETTATO STUDIATO PER ESEGUIRE, SU TUTTI I TIPI DI PIASTRELLE, JOLLY A 45°, SMUSSI E PROFILI CON RAGGIO 3 - 5 E 10MM. PRONTO ALL'USO • SEMPLICE • VELOCE • PRECISO • MANEGGEVOLE

PATENTED SYSTEM ESPECIALLY DESIGNED TO CREATE 45° DEGREE AND ROUND PROFILES ON ALL CERAMIC, PORCELAIN AND SLAB TILES. READY FOR USE • SIMPLE • FAST • PRECISE • EASY TO HANDLE

SYSTÈME BREVETÉ ADAPTÉ SURTOUT POUR LE GRÈS CÉRAME ET SUR DEMANDE, AUTRES PROFILS DES MEULES JUSQU'À 15MM D'ÉPAISSEUR - CHANFREIN 45° DE 3MM ET 5MM - RAYON DE 3MM/5MM ET 10MM. LIVRÉ PRÊT À L'EMPLOI • CHANGEMENT SIMPLE DE LA FRAISE • TRAVAIL PRÉCIS ET RAPID • UTILISATION PRATIQUE

PATENTIERTES SYSTEM EIGNET SICH FÜR JEDES FEINSTEINZEUG AUF WUNSCH MIT ZUSÄTZLICHEN FRÄSKÖPFEN BIS 15MM HOHE FLIESEN - FASE 45° 3MM UND 5MM - RADIUS 3MM/5MM UND 10MM. EINSATZBEREIT GELIEFERT • EINFACHES AUSWECHSELN DER FRÄSKÖPFE • RASCHE BEARBEITUNG • PRÄZISE AUSFÜHRUNG DER OBERFLÄCHEN • EINFACH IN DER HANDHABUNG



Art.				€
SUPERPROFILE	230 V~ · 780 W · 50/60 Hz · 11.000 RPM	5,0	C/1	488,00
SUPERPROFILE-115V	110/120 V~ · 780 W · 50/60 Hz · 11.000 RPM	5,0	C/1	494,00

MOLA DIAMANTATA INCLUSA - DIAMOND TOOL INCLUDED - FRAISE DIAMANTÉE INCLUSE - DIAMANT-FRÄSKOPF ENTHALTEN: art. FPE115SP





Motore potente, disco Ø 250mm
Powerful 3hp engine, Blade Ø 250mm
 Puissance moteur: 3HP, disque diamant Ø 250 mm
Kraftvoller 3PS-Motor, 250mm Scheibendurchmesser

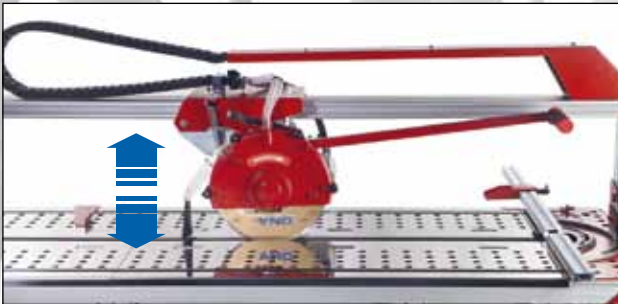

Testa regolabile in altezza
Height adjustable Head
 Hauteur de tête réglable
Kopf höhenverstellbar



Testa inclinabile per Jolly
Tilting head for Jolly
 Tête inclinable pour faire des biseaux
Neigbar für Jolly-Schnitte



Bloccaggio della piastrella "Squeeze patented system"
Patented "Squeeze" Tile Locking System
 «Système breveté Squeeze» verrouillage des carreaux
Patentiertes Klemmsystem zur Fliesenfixierung

Piani in acciaio inox
 Stainless steel work surfaces
 Pieds en acier inoxydable
 Arbeitsflächen aus Edelstahl



Struttura in alluminio ed acciaio rinforzato zincato e verniciato
Aluminum frame, reinforced with painted galvanized steel
 Cadre en aluminium, renforcé par de l'acier galvanisé
Aluminium-Rahmen, verstärkt mit lackiertem, galvanisiertem Stahl

F1
BROOKLYN

F1

BROOKLYN



Vasca estraibile in "ABS" antiurto
Removable tank made in "ABS" shockproof plastic
 Bac extractible en plastique ABS (résistant au choc)
 Herausnehmbarer Tank aus stoßfestem ABS-Kunststoff



Pratica, leggera e compatta
Practical, lightweight and compact
 Pratique, légère et compacte
 Praktisch, leicht und kompakt



Squadra goniometrica
Goniometrical Square
 Équerre goniométrique
 Goniometrischer Anschlagwinkel



Sistema brevettato per una planarità ottimale (151/181cm)
Patented adjustable legs system (151/181cm)
 Système breveté pour une planéité optimale (151/181cm)
 Patentiertes, einstellbares Beinsystem (151/181cm)

RICAMBI • SPARE PARTS
PIECES DETACHEES • ERSATZTEILE

Art.			€
	MOTORE MOTOR MOTEUR MOTOR		
1080MB	230V~/2,2kW	V/1	338,00
1081MB	115V~/1,5kW	V/1	349,00
	POMPA ELETTRICA AD IMMERSIONE ELECTRIC IMMERSION PUMP POMPE ELECTRIQUE IMMERGEE ELEKTRISCHE TOUCHPUMPE		
1082	230V~ x mod.101-131cm	V/1	86,00
1082F1	230V~ x mod.151-181cm	V/1	182,00
1083	115V~ x mod.101-131cm	V/1	85,00
1083F1	115V~ x mod.151-181cm	V/1	216,00
	INTERRUTTORE SWITCH INTERRUPTEUR SCHALTER		
1191	230V~	V/1	91,00
1155	115V~	V/1	102,00
	VASCA TANK CUVE WANNE		
1206F1		V/1	78,00
	CARTER COPRIDISCO BLADE GUARD CARTER COUVRE DISQUE SPRITZSCHUTZHAUBE DER DIAMANTSCHLEIBE		
1208F1		V/1	52,00
	CURSORE CON CUSCINETTO SLIDER WITH BEARING CURSEUR AVEC ROULEMENT ROLLEN MIT KUGELLAGER		
1195		V/1	14,00
	SUPPORTO UPRIGHT PALIER STÄNDER		
1095F1SX	SX	V/1	48,00
1095F1DX	DX	V/1	48,00
	SQUADRA GONIOMETRICA GONIOMETRICAL SQUARE EQUERRE GONIOMETRIQUE WINKELANSCHLAG		
1089EV	x mod. 101-131cm	V/1	72,00
1198EV	x mod. 151-181cm	V/1	74,00
	RIGHETTE MEASUREMENT GUIDE STICKERS REGLES MASSTÄEBEN		
1073EV		V/1	22,00
	NASELLO MEASUREMENT SQUARE MENTONNET NASE		
1201		V/1	20,00
	RUOTA WHEEL ROUE RAEDER		
302F1		V/1	12,00

OPTIONAL

Art. 58E

€ 58,00



TAPPETINO IN GOMMA PER MOSAICO, PIASTRELLE IN VETRO, DELICATE O SOTTILI (3MM)
RUBBER PAD FOR MOSAIC TILES, PLUS DELICATE AND VERY THIN 3MM GLASS TILES
TAPIS EN CAOUTCHOUC POUR CARREAUX DE MOSAÏQUE, DU VERRE ET DU CARRELAGE FIN ET DÉLICAT (3MM)
GUMMIMATTE FÜR MOSAIKFLESEN, GLAS, ZERBRECHLICHEN UND DÜNNEN FLIESEN (3MM)

OPTIONAL

Art. 1305F1

€ 380,00



KIT DI AVANZAMENTO CON VOLANTINO • HAND WHEEL FEED KIT
KIT POUR AVANCE AVEC MANIVELLE • SET FÜR VORSCHUB MIT SPINDEL - (STANDARD X MOD. 181CM)

OPTIONAL

Art. 1051

€ 154,00



TAVOLINO DI SUPPORTO • SUPPORT TABLE • TABLE DE SUPPORT • STÜTZTISCH

F1 BROOKLYN

TAGLIERINA ELETTRICA AD ACQUA • ELECTRIC, WATER-COOLED DIAMOND TILE SAWS
 DÉCOUPEUSE ÉLECTRIQUE À EAU • ELEKTRISCHE SCHNEIDEMASCHINE MIT WASSERKÜHLUNG



art. F1-101cm



art. F1-131cm



art. F1-151cm

NEW
 PATENTED
 ADJUSTABLE
 LEGS SYSTEM
 151/181cm

art. F1-181cm

Art.												€
		cm	inch	cm	inch	cm	inch	mm	inch			
F1-101	230V~/2,2kW (3HP)	101	40	71 x 71	28 x 28	0 ÷ 5	0 ÷ 2	250/25,4	10 / 1	75	C/1	1.860,00
F1-131	230V~/2,2kW (3HP)	131	51,5	92 x 92	36 x 36	0 ÷ 5	0 ÷ 2	250/25,4	10 / 1	85	C/1	1.960,00
F1-151	230V~/2,2kW (3HP)	151	59,5	106 x 106	41,5 x 41,5	0 ÷ 5	0 ÷ 2	250/25,4	10 / 1	100	C/1	2.330,00
F1-181	230V~/2,2kW (3HP)	181	71,5	128 x 128	50 x 50	0 ÷ 5	0 ÷ 2	250/25,4	10 / 1	112	C/1	2.840,00
F1-101-115V	115V~/1,5kW (2HP)	101	40	71 x 71	28 x 28	0 ÷ 5	0 ÷ 2	250/25,4	10 / 1	75	C/1	1.910,00
F1-131 -115V	115V~/1,5kW (2HP)	131	51,5	92 x 92	36 x 36	0 ÷ 5	0 ÷ 2	250/25,4	10 / 1	85	C/1	2.010,00
F1-151 -115V	115V~/1,5kW (2HP)	151	59,5	106 x 106	41,5 x 41,5	0 ÷ 5	0 ÷ 2	250/25,4	10 / 1	100	C/1	2.410,00
F1-181 -115V	115V~/1,5kW (2HP)	181	71,5	128 x 128	50 x 50	0 ÷ 5	0 ÷ 2	250/25,4	10 / 1	112	C/1	2.930,00

DISCO DIAMANTATO INCLUSO - DIAMOND BLADE INCLUDED - DISQUE DIAMANTÉ INCLUSE - DIAMANT-TRENNSCHEIBE ENTHALTEN: SCX

RICAMBI • SPARE PARTS
PIECES DETACHEES • ERSATZTEILE

Art.			€
	MOTORE MOTOR MOTEUR MOTOR		
1278		V/1	238,00
	POMPA ELETTRICA AD IMMERSIONE ELECTRIC IMMERSION PUMP POMPE ELECTRIQUE IMMERGEE ELEKTRISCHE TOUCHPUMPE		
1287		V/1	92,00
	TAVOLINO DI SUPPORTO SUPPORT TABLE TABLE DE SUPPORT STÜTZTISCH		
1255		V/1	42,00
	RUBINETTO WATER TAP ROBINET WASSERHAHN		
1286		V/1	3,50
	VASCA TANK CUVE WANNE		
1262		V/1	42,00
	INTERRUTTORE DIFFERENZIALE DIFFERENTIAL SWITCH DISJONCTEUR DIFFERENTIEL FEHLERSTROM-SCHUTZSCHALTER		
1288		V/1	64,00
	CARBONCINI CARBON BRUSH BALAIS DE CHARBON KOHLENBÜRSTEN		
1280	Set 2 pcs.	B/1	9,00
	PROTEZIONE TERMICA THERMAL PROTECTION PROTECTION THERMIQUE WÄRMESCHUTZ		
1296		B/1	10,00
	ESTENSIONE VASSOIO PER ACQUA EXTENSION OF WATER TRAY PROLONGATEUR DE PLATEAU POUR L'EAU FACHVERLÄNGERUNG FÜR WASSER		
1256		V/1	18,00
	SQUADRA GONIOMETRICA GONIOMETRICAL SQUARE EQUERRE GONIOMETRIQUE WINKELANSCHLAG		
1250		V/1	54,00
	RIGHETTE MEASUREMENT GUIDE STICKERS REGLES MASSTAEBEN		
1293	Set 5 pcs.	V/1	6,00

INCLINAZIONE
MICROMETRICA CON LED

ADJUSTABLE MICRO
METRICAL TILT WITH LED

MICRO INCLINAISON MÉTRIQUE
ORIENTABLE AVEC LED

EINSTELLBARE MIKRO METRISCHE
NEIGUNG MIT LED



REGOLAZIONE IN ALTEZZA

VERTICAL ADJUSTABLE HEAD

TÊTE RÉGLABLE VERTICAL

VERTIKAL VERSTELLBARE KOPF



TRACCIATORE
LINEARE LASER

LINEAR LASER
MARKER

MARQUEUR LASER
LINÉAIRE

TRACER
LINIENLASER



SISTEMA DI
TRASPORTO
"TROLLEY"

"TROLLEY"
TRANSPORT
SYSTEM

SYSTÈME DE
TRANSPORT
"TROLLEY"

"TROLLEY"-
TRANSPORTSYSTEM









TORNADO

TAGLIERINA ELETTRICA AD ACQUA • *ELECTRIC, WATER-COOLED DIAMOND TILE SAWS*
 DÉCOUPEUSE ÉLECTRIQUE À EAU • *ELEKTRISCHE SCHNEIDEMASCHINE MIT WASSERKÜHLUNG*

**SUPER VELOCE
 HIGH SPEED
 RPM 4300 min⁻¹**



Art.												€
		cm	inch	cm	inch	cm	inch	mm	inch			
970T	230V~/1,8kW (2,5HP)	70	27,5	50 x 50	19,5 x 19,5	0 ÷ 9	0 ÷ 3,5	250/25,4	10 / 1	53 (36+17)	C/1	1.378,00

DISCO DIAMANTATO INCLUSO - *DIAMOND BLADE INCLUDED* - DISQUE DIAMANTÉ INCLUSE - *DIAMANT-TRENNSCHEIBE ENTHALTEN*: SCX 

RICAMBI • SPARE PARTS				PIECES DETACHEES • ERSATZTEILE			
Art.		€	Art.		€		
						MOTORE MOTOR MOTEUR MOTOR	
1001	230V~/0.9kW x artt. 910-930-933	V/1	183,00				
1002	115V~/0.9kW x artt. 911-931-934	V/1	207,00				
1030	230V~/2kW x artt. 920-964	V/1	274,00				
1031	115V~/2kW x artt. 921-965	V/1	288,00				
						INTERRUTTORE SWITCH INTERRUPTEUR SCHALTER	
1032	Con cavo x artt. 921-965	V/1	205,00				
1055	Con cavo x artt. 910-930-933	V/1	63,00				
1056	Con cavo x artt. 920-964	V/1	65,00				
1057	Con cavo x artt. 911-931-934	V/1	96,00				
						VASCA E RIPARO WATER TROUGH CUVE AVEC PROTECTION WANNE MIT SCHUTZ	
1007	x artt. 910-911-930-931-933-934	V/1	86,00				
1036	x artt. 920-921-964-965	V/1	108,00				
						CUFFIA POLIFUNZIONALE MULTI-FUNCTION BLADE GUARD PROTECTION MULTIFONCTIONS HAUBE MIT MEHREREN FUNKTIONEN	
1008	x artt. 910-911-933-934	V/1	58,00				
1024	x artt. 930-931	V/1	66,00				
1037	x artt. 920-921-964-965	V/1	78,00				
						COPPIA BUSSOLE SEALED BEARINGS COUPLE DE DOUILLES KUGELBUCHSENPAAR	
1015	x artt. 930-931-933-934-964-965	V/1	74,00				
						TAPPETO E GUIDA NON-SLIP MAT TAPIS ET GUIDE TEPPICH UND FÜHRUNG	
1004	x artt. 933-934	V/1	24,00				
1033	x artt. 930-931-964-965	V/1	25,00				
						CONTENITORE ACQUA WATER TANK CUVE D'EAU WASSERBEHALTER	
1005	x artt. 910-911-930-931-933-934	V/1	56,00				
1010	x artt. 920-921-964-965	V/1	58,00				
						RIGHETTE MEASUREMENT GUIDE STICKERS REGLES MASSTAEBEN	
1019	x artt. 910-911-930-931-933-934	V/1	28,00				
1060	x artt. 920-921-964-965	V/1	31,00				
						NASELLO MEASUREMENT SQUARE MENTONNET NASE	
1013	x artt. 930-931-933-934-964-965	V/1	38,00				



RICAMBI • SPARE PARTS				PIECES DETACHEES • ERSATZTEILE			
Art.		€	Art.		€		
						MOTORE MOTOR MOTEUR MOTOR	
1092EV	230V~/0,55kW	V/1	108,00				
						INTERRUTTORE SWITCH INTERRUPTEUR SCHALTER	
1096EV		V/1	24,00				
						VASCA TANK CUVE WANNE	
1116EV		V/1	8,00				
						CARTER COPRIDISCO BLADE GUARD CARTER COUVRE DISQUE SPRITZSCHUTZHAUBE DER DIAMANTSCHLEIFE	
1110EV		V/1	8,00				
						RIGA LUNGA LONG ROD REGLE LONGUE LANGER MAßSTAB	
1113EV		V/1	13,00				
						SQUADRA PER DIAGONALE SQUARE FOR DIAGONAL CUTS EQUERRE POUR COUPES DIAGONALES WINKEL FÜR DIAGONALE SCHNITTE	
1114EV		V/1	4,00				



ELETTROMONTOLIT

TAGLIERINA ELETTRICA AD ACQUA • *ELECTRIC, WATER-COOLED DIAMOND TILE SAWS*
 DÉCOUPEUSE ÉLECTRIQUE À EAU • *ELEKTRISCHE SCHNEIDEMASCHINE MIT WASSERKÜHLUNG*



Art.												€
		cm	inch	cm	inch	cm	inch	mm	inch			
930	230V~/0,9kW (1,2HP)	50	19,5	35 x 35	14 x 14	0 ÷ 5,5	0 ÷ 2-1/8	230/30	9 / 1-3/16	51	C/1	1.278,00
931	115V~/0,9kW (1,2HP)	50	19,5	35 x 35	14 x 14	0 ÷ 5,5	0 ÷ 2-1/8	230/30	9 / 1-3/16	51	C/1	1.321,00

DISCO DIAMANTATO INCLUSO - *DIAMOND BLADE INCLUDED* - DISQUE DIAMANTÉ INCLUSE - *DIAMANT-TRENNSCHEIBE ENTHALTEN*: CPH

MINIELETTROMONTOLIT

TAGLIERINA ELETTRICA AD ACQUA • *ELECTRIC, WATER-COOLED DIAMOND TILE SAWS*
 DÉCOUPEUSE ÉLECTRIQUE À EAU • *ELEKTRISCHE SCHNEIDEMASCHINE MIT WASSERKÜHLUNG*



Art.												€
		cm	inch	cm	inch	cm	inch	mm	inch			
905EV	230V~/0,55kW (0,7HP)	Illimitato - <i>Unlimited</i> Illimité - <i>Unbeschränkt</i>		25 x 25	10 x 10	0 ÷ 3,5	0 ÷ 1-3/8	180/22,2	7 / 7/8	12	C/1	218,00

DISCO DIAMANTATO INCLUSO - *DIAMOND BLADE INCLUDED* - DISQUE DIAMANTÉ INCLUSE - *DIAMANT-TRENNSCHEIBE ENTHALTEN*:

BIMBO FORATUTTO

ELETTROFORATRICE AD ACQUA PER FRESE DIAMANTATE

ELECTRIC, WATER-COOLED COREBIT DRILLS

PERCEUSE ELECTRIQUE À FRAISES DIAMANTÉES (UTILISATION À EAU)

ELEKTROBOHRMASCHINE FÜR WASSERGEKÜHLTE DIAMANTFRÄSER



OPTIONAL

COLONNA SUPPORTO
SUPPORT
SUPPORT
UNTERSTÜTZUNG



Art. 995

€ 432,00

RICAMBI • SPARE PARTS PIECES DETACHEES • ERSATZTEILE

Art.			€
	MOTORE MOTOR MOTEUR MOTOR		
1075	230V~/0.4kW x art. 915	V/1	236,00
1076	115V~/0.4kW x art. 916	V/1	239,00
	INTERRUTTORE SWITCH INTERRUPTEUR SCHALTER		
1003	Con tasto bianco	V/1	34,00
1053	230V~	V/1	34,00
	INTERRUTTORE DIFFERENZIALE DIFFERENTIAL SWITCH DISJONCTEUR DIFFERENTIEL FEHLERSTROM-SCHUTZSCHALTER		
1077	x art. 915	V/1	156,00
1079	x art. 916	V/1	128,00
	CONTENITORE ACQUA WATER TANK CUVE D'EAU WASSERBEHALTER		
1072		V/1	43,00

Art.									€
		M16 Optional: W5/8"	max mm	max inch	cm	inch	kg		
915	230V~/0,4kW (0,55HP)		120	4-3/4	0 ÷ 4,5	0 ÷ 1-3/4	17	C/1	824,00*
916	115V~/0,4kW (0,55HP)		120	4-3/4	0 ÷ 4,5	0 ÷ 1-3/4	17	C/1	842,00*

pag. 74 * FRESE DIAMANTATE NON INCLUSE • * DIAMOND CUTTERS NOT INCLUDED
* FRAISES DIAMANTEES PAS INCLUSES • * OHNE DIAMANT-BOHRKRONEN

FORAPIASTRELLE • TILE DRILLS

PERCEUSE À CARREAUX • FLIESEN-LOCHSCHNEIDER



RICAMBI • SPARE PARTS PIECES DETACHEES • ERSATZTEILE

Art.			€
	UTENSILE RADIAL TOOL OUTIL WERKZEUG		
236		B/6	18,00
	PUNTA CENTRALE CENTRAL BIT POINTE CENTRALE ZENTRALSPITZE		
237		B/6	11,00
	MARTELLETTO HAMMER MARTELET HAMMER		
235		V/1	8,00

Art.							€
	cm	inch	mm	inch	kg		
18	30 x 30	12 x 12	20 ÷ 80	3/4 ÷ 3	2,5	C/1	136,00



Art. EM18D

Art. EM18W

Art.				UTILIZZO USE			€
		max mm			kg	BOX	
EM18D	230V~1,8kW (2,4HP) 1000/2600 rpm	180	M16		6,5	C/1	1.094,00
EM18W	230V~1,8kW (2,4HP) 1000/2600 rpm	180	M16 1/2"gas -1-1/4"	+ +	7,3	C/1	1.488,00
EM25W	230V~2,5kW (3,35HP) 200/590 rpm	250	1/2"gas -1-1/4"		11,5	C/1	2.794,00
EM33W	230V~3,3kW (4,4HP) 230/730 rpm	350	1/2"gas -1-1/4"		12,5	C/1	3.386,00

pag. 22

ASPIRATORE PROFESSIONALE PER POLVERI E LIQUIDI • PROFESSIONAL VACUUM CLEANER FOR DUST AND LIQUIDS
 ASPIRATEUR PROFESSIONNEL POUR POUDRE ET LIQUIDE • PROFI-SAUGER FÜR STAUB UND FLÜSSIGKEIT

pag. 57

FORETTI DIAMANTATI E ACCESSORI • DIAMOND CORE-DRILLS AND FITTINGS
 FORETS DIAMANTES ET ACCESSOIRES • DIAMANTBOHRKRONEN UND ZUBEHÖR

SUPPORTO PER CAROTTRICI • SUPPORT FOR CORE DRILLING MACHINES
 SUPPORT POUR MACHINES DE CAROTTAGE • UNTERSTÜTZUNG FÜR KERNBOHRMASCHINEN



Art. EMB13



Art. EMB16



Art. EMB25







Art. EMB32

Art.							€
		max mm	mm		kg	BOX	
EMB13	0° ÷ 45° Predisposition of vacuum connection	150	600	Attacco rapido Quick connection	8	C/1	942,00
EMB16	0° ÷ 45° Predisposition of vacuum connection	200	450	Attacco rapido Quick connection	10	C/1	1.289,00
EMB25	0° ÷ 45° Optional: vacuum connection	250	800	Attacco rapido Quick connection	15	C/1	1.670,00
EMB32	0° ÷ 45° Optional: vacuum connection	300	550	Attacco rapido Quick connection	19	C/1	2.260,00



RICAMBI • SPARE PARTS
PIECES DETACHEES • ERSATZTEILE

Art.			€
	UGELLO DI NEBULIZZAZIONE SPRAY NOZZLES BUSE DE PULVERISATION SPRITZDÜSE		
EMUGE		B/1	12,00
	PROLUNGA IDRAULICA HYDRAULIC EXTENSION EXTENSION HYDRAULIQUE HYDRAULISCHER ERWEITERUNG		
PLD9	Lunghezza 8 m.	B/1	92,00
	VALVOLA DI REGOLAZIONE CON CONNETTORE ADJUSTMENT VALVE WITH CONNECTOR VANNE DE REGLAGE AVEC CONNECTEUR EINSTELL VENTIL UND CONNECTOR		
EMR002		B/1	49,00
	DISTRIBUTORE CON INIETTORE E RACCORDO CON FILTRO DISTRIBUTOR WITH INJECTOR AND CONNECTION WITH FILTER DISTRIBUTEUR AVEC INJECTEUR ET LA CONNEXION AVEC FILTER VERTEILER MIT INJEKTOR UND MIT FILTER		
EMR003		B/1	48,00

OPTIONAL

PROTEZIONE UNIVERSALE DI GOMMA PER SMERIGLIATRICI
UNIVERSAL RUBBER PROTECTION FOR GRINDERS
PROTECTION DE CAOUTCHOUC UNIVERSELLE POUR PONCEUSES
UNIVERSAL GUMMISCHUTZ FÜR SCHLEIFER

Art. EMR015

€ 44,00



AQUAFLEX SYSTEM

SISTEMA UNIVERSALE PROFESSIONALE PER L'ABBATTIMENTO DELLE POLVERI SU SMERIGLIATRICI ANGOLARI





UNIVERSAL PROFESSIONAL SYSTEM FOR ELIMINATING THE DUST USING THE ANGLE-GRINDERS

SYSTÈME UNIVERSEL PROFESSIONNEL POUR L'ELIMINATION DE LA POUSSIÈRE AU COURSE DE L'EMPLOY DES PONCEUSES ANGULAIRES

PROFESSIONELLE STAUBABSAUGUNG FÜR WINKELSCHLEIFER



* Smerigliatrici angolari e dischi diamantati non inclusi
Grinding machines and diamond blades not included

Art.						€	
	mm	inch	V~	max W	kg	C/1	
EM115	115	4,5	230	2.500	11,5	C/1	802,00
EM125	125	5	230	2.500	11,5	C/1	806,00
EM180	180	7	230	2.500	11,7	C/1	820,00
EM230	230	9	230	2.500	11,9	C/1	834,00
EM2x180	180	7	230	2.500	12,6	C/1	978,00
EM115-110V	115	4,5	110	1.800	12,5	C/1	854,00
EM125-110V	125	5	110	1.800	12,5	C/1	858,00
EM180-110V	180	7	110	1.800	12,7	C/1	870,00
EM230-110V	230	9	110	1.800	12,9	C/1	878,00
AM115	115	4,5	Carter x Ø 115mm		0,25	C/1	144,00
AM125	125	5	Carter x Ø 125mm		0,30	C/1	146,00
AM180	180	7	Carter x Ø 180mm		0,65	C/1	148,00
AM230	230	9	Carter x Ø 230mm		0,70	C/1	158,00
AM2x180	180	7	Carter x 2 Ø 180mm		1,35	C/1	296,00

RICAMBI • SPARE PARTS				PIECES DETACHEES • ERSATZTEILE			
Art.			€	Art.			€
	MARTINETTO JACK VERIN HEBEBOCK				COPPIA LAMIERE METAL SUPPORT TABLES TOLES PAAR STAHLBLECHE		
225	x artt. 2-3-3ST-3STR	V/1	760,00	309	x art. 4H	V/1	22,00
226	x art. 4H	V/1	442,00				
	RUOTA WHEEL ROUE RAEDER				POMOLO ADJUSTMENT SCREW POMMEAU EINSTELLSCHRAUBE		
301	x artt. 2-2J-3-3ST-3STR	V/1	17,00	209	x art. 4H	V/1	38,00
302	x art. 4H	V/1	8,00				
	MOLLA SPRING RESSORT FEDER				COPPIA LAME BLADE SETS PAIRE DE LAMES MESSERPAAR		
216S	x art. 3-3S-3STR	V/1	12,00	200	x art. 3	V/1	168,00
217	x art. 4H	V/1	9,00	200S	x art. 3ST	V/1	155,00
220	x artt. 2-2J	V/1	15,00	206STR	x art. 3STR	V/1	191,00
				205	x art. 4H	V/1	111,00



RICAMBI • SPARE PARTS				PIECES DETACHEES • ERSATZTEILE			
Art.			€	Art.			€
	MARTINETTO JACK VERIN HEBEBOCK				COPPIA LAME BLADE SETS PAIRE DE LAMES MESSERPAAR		
225A		V/1	760,00	200	x art. 3A	V/1	168,00
				206STR	x art. 3STRA	V/1	191,00
	MOLLA SPRING RESSORT FEDER						
216S		V/1	12,00				





Art. 4H



Art. 3STR

Art.								€
	cm	inch	cm	inch				
3STR	61	24	0 ÷ 23,5	0 ÷ 9-1/4	25.000	118	V/1	1.538,00
4H	41	16	2 ÷ 15,5	3/4 ÷ 6-1/8	10.000	55	V/1	768,00

FAST HYDROTRONK

TRONCALASTRE IDROPNEUMATICO • HYDROPNEUMATIC SLAB CUTTERS • DÉCOUPEUSE HYDROPNEUMATIQUE • HYDROPNEUMATISCHE PLATTENSCHNEIDER



MINIMUM
20 lt - 6 bar

Art.								€
	cm	inch	cm	inch				
3STRA	61	24	0 ÷ 23,5	0 ÷ 9-1/4	25.000	124	V/1	2.078,00



Art. 4



Art. 6L



Art. 4L

Art.								€
	cm	inch	cm	inch				
4	41	16	2 ÷ 15,5	3/4 ÷ 6-1/8	4.100	60	V/1	454,00
4KKS	41	16	10 ÷ 23	4 ÷ 9	4.100	67	V/1	498,00
4L	41	16	0 ÷ 10	0 ÷ 4	4.100	45	C/1	384,00
6L	31	12	0 ÷ 10	0 ÷ 4	4.100	29	C/1	332,00

PINZONI

PINZE DI SOLLEVAMENTO PER CORDOLI • KERB STONE HANDLES • PINCES MANUELLE POUR LA POSE DE BORDURES • BORDSTEINZANGE ZUM SETZEN VON BORDSTEINEN







Art. 16



Art. 16-40

Art.			PORTATA MAX MAX LOAD			€
	cm	inch				
16	5 ÷ 18	2 ÷ 7 1/8	200	11	C/1	204,00
16-40	18 ÷ 40	7 1/8 ÷ 16	300	18,3	C/1	332,00

RICAMBI • SPARE PARTS • PIECES DETACHEES • ERSATZTEILE

Art.			€	Art.			€
 <p>COPPIA LAME BLADE SETS PAIRE DE LAMES MESSERPAAR</p>				 <p>MOLLA SPRING RESSORT FEDER</p>			
201	x art. 5	V/1	49,00	221	x art. 5	V/1	7,00
202	x art. 7	V/1	61,00	222	x art. 7	V/1	6,00
202N	x art. 7N	V/1	44,00	222N	x art. 7N	V/1	6,00
203	x art. 9	V/1	79,00	223	x art. 9	V/1	7,00
203N	x art. 9N	V/1	59,00	223N	x art. 9N	V/1	8,00
204	x art. 11	V/1	115,00	224	x art. 11	V/1	8,00
 <p>POMOLO ADJUSTMENT SCREW POMMEAU EINSTELLSCHRAUBE</p>							
210	x art. 5	V/1	18,00				
211	x art. 7	V/1	19,00				
212	x art. 9	V/1	22,00				
213	x art. 11	V/1	28,00				

OPTIONAL





TAVOLINO DI SUPPORTO
SUPPORT TABLE
TABLE DE SUPPORT
STÜTZTISCH



Art. 190



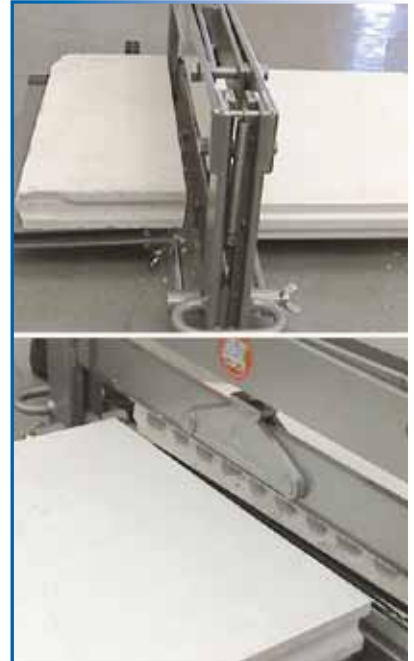

€ 51,00

RICAMBI • SPARE PARTS • PIECES DETACHEES • ERSATZTEILE

Art.			€	Art.			€
 <p>COPPIA LAME BLADE SETS PAIRE DE LAMES MESSERPAAR</p>				 <p>MOLLA SPRING RESSORT FEDER</p>			
207	x art. 12	V/1	138,00	217	x art. 12	V/1	9,00
207N	x art. 12N	V/1	138,00	218L	x art. 12N	V/1	9,00
 <p>POMOLO ADJUSTMENT SCREW POMMEAU EINSTELLSCHRAUBE</p>				 <p>RUOTA WHEEL ROUE RAEDER</p>			
228		V/1	41,00	302		V/1	8,00



RICAMBI • SPARE PARTS
PIECES DETACHEES • ERSATZTEILE

Art.			€
 <p>COPPIA LAME BLADE SETS PAIRE DE LAMES MESSERPAAR</p>			
270	x art. 32	B/1	18,00
271	x art. 42	B/1	20,00
 <p>COPPIA MOLLE SPRING SETS PAIRE DE RESSORTS FEDERPAAR</p>			
215	x art. 42	B/1	6,00
 <p>MOLLA SPRING RESSORT FEDER</p>			
364	95mm x art. 32	B/1	6,00







TRANCIAMARMETTE UNIVERSALE • TERRAZZO/MARBLE FLOOR TILE CUTTERS
 DÉCOUPEUSE UNIVERSELLE • UNIVERSAL-PLATTENSCHNEIDER



Art. 11



Art. 9N

Art.								€
	cm	inch	cm	inch	kg	kg	BOX	
7N	41	16	0,5 ÷ 4,2	1/8 ÷ 1-5/8	1.000	30	C/1	230,00
9N	51	20	1,2 ÷ 5,5	0,5 ÷ 2	1.000	43	C/1	292,00
11	61	24	1,5 ÷ 6,5	5/8 ÷ 2,5	1.000	61	C/1	346,00

TRANCIAGESSO UNIVERSALE • UNIVERSAL PLASTER CUTTERS
 DÉCOUPEUSE À CX PLATRE ET CX BRIQUE UNIVERSELLE • GIPSPLATTEN-SCHNEIDER



**NEW
MODEL**

Art.								€
	cm	inch	cm	inch	kg	kg	BOX	
12N	72	28	4 ÷ 14	1,5 ÷ 5,5	2.000	57	V/1	542,00



TAGLIATEGOLE • ROOF TILE CUTTERS
 DÉCOUPEUSE A TUILES • DACHZIEGEL HANDSCHNEIDER



Art. 32



Art. 42

Art.				€
		kg	BOX	
32	Per tegole in cotto - For clay roof tiles	2,4	V/1	84,00
42	Per tegole in cemento e cotto - For clay roof tiles and concrete	7,0	C/1	176,00

MANIGLIA SOLLEVALASTRE PER LA MOVIMENTAZIONE E LA POSA DI LASTRE DI GRANDE FORMATO (MASSIMO 65X65 CM), ALTO SPESSORE E CON SUPERFICE STRUTTURATA.
 HANDLE LIFT SLABS FOR HANDLING AND LAYING LARGE FORMAT TILES & EXTERNAL SLABS OF HIGH THICKNESS AND WITH A STRUCTURED SURFACE - UP TO 65X65 CM MAXIMUM.
 ELÉVATEUR ET POSITIONNEUR POUR LE DÉPLACEMENT ET LA POSE DES CARREAUX CÉRAM FORTE ÉPAISSEUR (MAX. 65 X 65 CM).
 PLATTENHEBER FÜR DEN MANUELLEN TRANSPORT UND ZUM SETZEN VON FEINSTEINZEUG - GARTENPLATTEN (MAX. 65 X 65 CM).



NEW

Art.	cm	inch	BOX	€
16-S	50 ÷ 65	20 ÷ 25-3/4	C/2	76,00

VENTOSE PER PIASTRELLISTA • SUCKERS FOR TILE-LAYER
 VENTOUSES POUR CARRELEUR • SAUGNÄPFE FÜR FLIESEN



Art.	Ø	BOX	€
	mm		
VT80	80	B/1	8,00
300-76	200	C/1	148,00

KOPIA PROFILE

COPIA IL PROFILO DI OGGETTI DIFFICILI DA RIPIANTARE SULLA PIASTRELLA PRIMA DEL TAGLIO
 FOR COPYING THE OUTLINES OF KNOTTY THINGS TO TRANSFER ON THE TILES BEFORE CUTTING
 PERMETS LE RELÈVEMENT DU PROFIL D'OBJECTS DE FORMES DIFFICILES ET DE LE REPORTER SUR LES CARREAUX AVANT DE LES COUPER
 PROFILKOPIERLEHRE ZUM EINFACHEREN UEBERTRAGEN VON KOMPLIZIERTEN MOTIVEN AUF DIE ZU BEARBEITENDE FLIESE



Art.	BOX	€
60	V/1	48,00

ALTEZZA REGOLABILE • ADJUSTABLE HEIGHT
HAUTEUR RÉGLABLE • HÖHENVERSTELLBAR

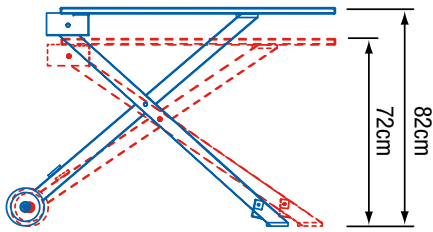

X-WORKS

BANCO DI LAVORO PER PIASTRELLISTA • WORK-TABLE FOR TILE-LAYER
TABLE DE TRAVAIL POUR CARRELEUR • ARBEITSTISCH FÜR FLIESENLEGER

NEW



Art.



X-WORKS

kg
15



C/1

€

284,00

® **MONTOLIT**

DOPPIO SISTEMA DI SPACCO
 DUAL SPLITTING SYSTEM
 DOUBLE SYSTÈME DE COUPE
 PARALLEL-BRECHSYSTEM

NEW



Art. 56R



Art.			€
56RJ	max 15 mm	S/1	94,00
56R	max 20 mm	S/1	124,00

TENAGLIA PER PIASTRELLISTA A BRANCHE INCISIVE APERTE
 TILE NIBBLER WITH OPEN CUTTING JAW

TENAILLE POUR CARRELEUR A MACHOIRES TRANCHANTES OUVÉRTES
 ZANGE FÜR FLIESENLEGER MIT OFFENEN SCHNITTBACKEN



Art.				€
33		g 435	S/6	19,00

TENAGLIA PER PIASTRELLISTA A BRANCHE INCISIVE REGOLABILI
 TILE NIBBLER WITH ADJUSTABLE CUTTING JAW

TENAILLE POUR CARRELEUR A MACHOIRES TRANCHANTES RÉGLABLES
 ZANGE FÜR FLIESENLEGER MIT EINSTELLBAREN SCHNITTBACKEN



Art.				€
54		g 230	S/6	19,00

TENAGLIA SPECIALE PER PIASTRELLE DURISSIME
 TILE NIBBLER DESIGNED ESPECIALLY FOR EXTRA HARD TILES

TENAILLE SPÉCIALE POUR CARREAUX TRÈS DURS
 ZANGE FÜR FLIESENLEGER SPEZIFISCH FÜR EXTREM HARTE-FLIESEN



Art.				€
55		g 350	S/6	19,00

TENAGLIA SPECIALE PER MOSAICO CERAMICO/VETRIFICATO E GRES PORCELLANATO
 TILE NIBBLER DESIGNED ESPECIALLY FOR CERAMIC/GLASS MOSAIC AND PORCELAIN

TENAILLE SPÉCIALE POUR MOSAÏQUE CERAMIQUE/VITRIFIÉ ET GRES CERAME
 ZANGE FÜR FLIESENLEGER SPEZIELL FÜR MOSAIK UND FEINSTEINZEUG



Art. 242TW - € 12,00





Art.				€
55W		g 360	S/6	28,00

GUMMY

MAZZETTE ANTIRIMBALZO IN GOMMA • RUBBER NON-REBOUND MALLETS
 MAILLET SANS REBOND EN CAOUTCHOUC • RÜCKSCHLAGFREIE HÄMMER, VOLLSTÄNDIG GUMMI





Art.			€
98	500	S/6	11,00
99	1.000	S/6	14,00

ENERGY



MAZZETTA PER PIASTRELLISTA, POSATORE, MURATORE • SLEDGE-HAMMER FOR TILE-LAYER, STONE FLOOR-LAYER, BRICK-LAYER
 MASSETTE POUR CARRELEUR, PAVEUR, MAÇON • HAMMER FÜR BODENLEGER UND MAURER



Art.			€
105	500	S/6	24,00



MARTELLLO DA CARPENTIERE BREVETTATO • PATENTED CLAW HAMMER
 MARTEAU POUR CHARPENTIER BREVETÉ • PATENTIERTER ZIMMERMANNSHAMMER



Art.			€	
91	Con manico 450mm	400	S/6	19,00

MAZZA PER LASTRE / AUTOBLOCCANTI • HAMMER FOR SLAB AND KEYBLOCK MATERIAL
 MASSE POUR FEUILLES/AUTOBLOQUANTS • VORSCHLAGHAMMER FÜR PLATTEN/SELBSTBLOCKIEREND



Art.			€	
93-94	Testa tonda e quadra	1.500	V/1	46,00

TORCIGLIONE • CLAW BAR
 TORTILLON • ZUSATZGERÄT ZUM EISENDREHEN



Art.		€
59	V/1	36,00

SQUADRE FALSE UNIVERSALI • UNIVERSAL FOLDING SQUARES
 FAUSSES ÉQUERRES UNIVERSELLES • UNIVERSAL WINKEL-KOPIERER



Art.	↔		BOX	€
	cm	inch		
61	20	8	V/1	32,00
62	30	12	V/1	36,00
63	50	20	V/1	44,00

LASER MEASURE

MISURATORE LASER • LASER METER • LASER MÈTRE • LASER-METER



Art.	BOX	€
71ML	S/2	154,00

QUBIK LASER

LASER AUTOLIVELLANTE • AUTOMATIC LASER LEVEL • LASER AUTORÉGLABLE • AUTOMATISCHE LASERNIVELLIERUNG



Art.	BOX	€
70AL	S/3	88,00

STRAIT-LINE®

TRACCIATORE LASER A 1 LINEA • 1 BEAM LASER LINE GENERATOR • GÉNÉRATEUR DE LIGNE LASER • TRACERLINIENLASER



Art.	BOX	€
69TL	S/5	92,00

STRAIT-LINE®

RILEVATORE DI MONTANTI • STUD FINDER • DÉTECTEUR DE MONTANTS • TRÄGER-DETEKTOR



Art.	BOX	€
68RL	S/5	52,00



Art.	Ø		mm	n°	mm	BOX	€
	mm	inch					
803	315	12,5	30/25,4	24	3,2	S/1	53,00
804	350	14	35/25,4	24	3,2	S/1	82,00

LAME CIRCOLARI UNIVERSALI PER LEGNO • UNIVERSAL CIRCULAR BLADES FOR TIMBER
LAMES CIRCULAIRES UNIVERSEL POUR BOIS • UNIVERSAL-STICHSÄGEBLÄTTER FÜR HOLZ



Art.	Ø		mm	n°	mm	BOX	€
	mm	inch					
810	250	10	35/25,4	40	3,2	S/1	41,00
812	300	12	35/25,4	48	3,2	S/1	56,00
813	315	12,5	30/25,4	48	3,2	S/1	57,00
814	350	14	35/25,4	54	3,4	S/1	87,00

WOOD CARVER

LAME CIRCOLARI PER LEGNO • CIRCULAR BLADES FOR TIMBER
LAMES CIRCULAIRES POUR LE BOIS • KREISSÄGEBLÄTTER FÜR HOLZ



- ATTENZIONE!** Verificare che l'utensile sia compatibile con la macchina sulla quale verrà montato consultandone il manuale d'uso e di sicurezza.
- ATTENTION!** Check that this blade is compatible with the machines to which it will be assembled consulting their instructions and safety handbooks.
- ATTENTION!** Contrôler que ce disque soit compatible avec les machines sur lesquelles il sera assemblé en consultant leurs manuels d'instructions et des règles de sécurité.
- ACHTUNG!** Achten Sie darauf, dass die Werkzeuge mit der Maschine, worauf diese montiert werden, kompatibel sind. Achten Sie auf die Gebrauchs- und Sicherheitsanleitung.

Art.	Ø		mm	n°	BOX	€
	mm	inch				
115LL	115	4,5	22,2	6	B/1	24,00
230LL	230	9	22,2	6	B/1	46,00

GRATTINO

DISCO PER SBAVATURA E LEVIGATURA IDEALE PER CARTONGESSO, LEGNO E PLASTICA
DISC FOR GRINDING SUITABLE FOR PLASTERBOARD, WOOD AND PLASTIC MATERIAL
DISQUE POUR BROYAGE APPROPRIÉ POUR PLAQUES DE PLÂTRE, BOIS ET PLASTIQUE MATÉRIEL
DISC ZUM SCHLEIFEN FÜR GIPSKARTON, HOLZ UND VON PLASTIK

- ATTENZIONE!** Verificare che l'utensile sia compatibile con la macchina sulla quale verrà montato consultandone il manuale d'uso e di sicurezza.
- ATTENTION!** Check that this blade is compatible with the machines to which it will be assembled consulting their instructions and safety handbooks.
- ATTENTION!** Contrôler que ce disque soit compatible avec les machines sur lesquelles il sera assemblé en consultant leurs manuels d'instructions et des règles de sécurité.
- ACHTUNG!** Achten Sie darauf, dass die Werkzeuge mit der Maschine, worauf diese montiert werden, kompatibel sind. Achten Sie auf die Gebrauchs- und Sicherheitsanleitung.



Art.	Ø		mm	BOX	€
	mm	inch			
115GL	115	4,5	22,2	B/1	15,00

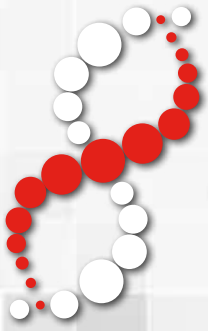

DIAMONDS NETWORK ARRANGEMENT

DNA EVO3

 **DNA** è una innovativa tecnologia che consiste nella particolare “distribuzione a rete tridimensionale controllata” dei granuli di diamante contenuti all’interno della parte tagliente degli utensili. In pratica e più semplicemente significa che i progettisti una volta determinata la concentrazione ideale (quantità ottimale di diamante all’interno delle miscele di polveri metalliche che poi saranno sottoposte a sinterizzazione) potranno poi “disporre” le singole grane di diamante a piacimento e secondo necessità.

Prima dell’avvento di questa tecnologia la disposizione dei granuli era casuale e la deposizione “organizzata” del diamante era possibile ma legata alla manualità dell’operatore e utilizzata esclusivamente per la messa a punto di specifici e costosissimi utensili, il rivoluzionario sistema **DNA** permette di trasformare questa operazione manuale in un processo automatico per la produzione in serie. Con **DNA** i settori diamantati e comunque tutte le parti taglienti sinterizzate dell’utensile, contenendo la stessa e predefinita quantità di granuli distribuiti con micrometrica precisione, presentano le medesime caratteristiche ottimali espressamente progettate per l’ottenimento delle migliori performances.

 **DNA** Montolit is an high technology system of arrying diamond particle that is revolutionary for the mass production of Diamond Cutting Tools. **DNA** uses Montolit - Worldwide Patented - Technology involving a Tri-dimensional net to control the perfect concentration, arrangement and positioning of diamonds in both the mix and placement on the cutting tool – till now virtually impossible to achieve due to manual operations.

The new Technological Process now allows Mass Production, formerly unobtainable with old methods, and also provides unique warranty of performance during operation plus greater life expectancy of the cutting tool. Uniquely the Tri-dimensional structure of the **DNA** translates to equality of levels, so when the upper diamond level is used up, the next level is ready to substitute it with the same fantastic characteristics.

 **DNA** est une technologie innovante qui consiste en une « distribution particulière en réseau tridimensionnelle contrôlée » des granulés de diamant contenus à l’intérieur de la partie coupante des outils. Dans la pratique et plus simplement, cela signifie que les concepteurs, une fois la concentration idéale déterminée (quantité optimale de diamants dans les mélanges de poussières métalliques qui seront ensuite soumises à un frittage) pourront ensuite « disposer » chaque grain de diamant au plaisir et selon les besoins.

Avant l’avènement de cette technologie, la disposition des granulés se faisait au hasard et la déposition « organisée » du diamant était possible mais liée à la manualité de l’opérateur et utilisée exclusivement pour la mise au point d’outils spécifique et très coûteux, le système **DNA** révolutionnaire permet de transformer cette opération manuelle en un processus automatique pour la production en série. Avec **DNA**, les secteurs diamantés et dans tous les cas, toutes les parties coupantes frittées de l’outil, contenant la même quantité prédéfinie de granulés distribués avec une précision micrométrique, présentent les mêmes caractéristiques optimales expressément conçues pour l’obtention des meilleures performances.

 **DNA** ist eine innovative Technologie, die in der besonderen „gesteuerten Verteilung in dreidimensionalem Netz“ der im Inneren des Schneidteils der Werkzeuge enthaltenen Diamantkörner besteht. In der Praxis und einfacher erklärt, bedeutet dies, dass, nachdem die Planer die Idealkonzentration (optimale Menge an Diamantpulver im Inneren der Mischungen aus Metallpulver, die anschließend dem Sintern unterzogen werden) bestimmt haben, sie die einzelnen Diamantkörper nach Belieben und nach Bedarf „anordnen“ können.

Vor dem Aufkommen dieser Technologie war die Anordnung der Körner zufällig und die „gesteuerte“ Anordnung des Diamantpulvers war möglich, jedoch an die Handfertigkeit des Fertigers gebunden und wurde ausschließlich für die Feinabstimmung bestimmter und äußerst teurer Werkzeuge benutzt; nun ermöglicht das revolutionäre **DNA**-System, diesen manuellen Vorgang in ein automatisches Verfahren für die Serienproduktion zu verwandeln. Mit **DNA** weisen die diamantbeschichteten Bereiche und jedenfalls alle gesinterten Schneidteile des Werkzeugs, die die gleiche und vorbestimmte Menge von mit mikrometrischer Genauigkeit verteilten Körner enthalten, die gleichen optimalen Eigenschaften auf, die ausdrücklich für die Erlangung der besten Leistungen geplant wurden.

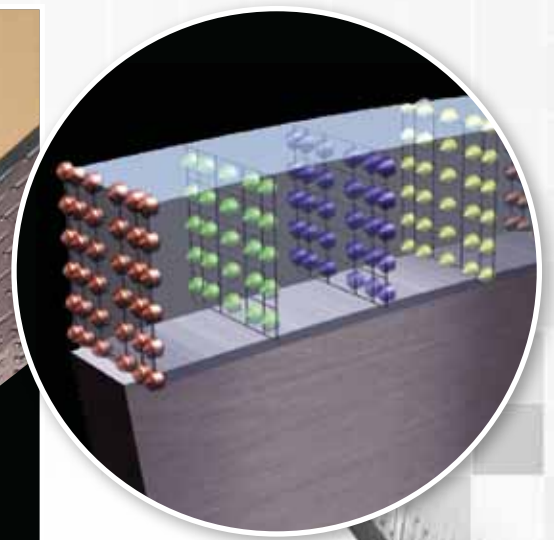
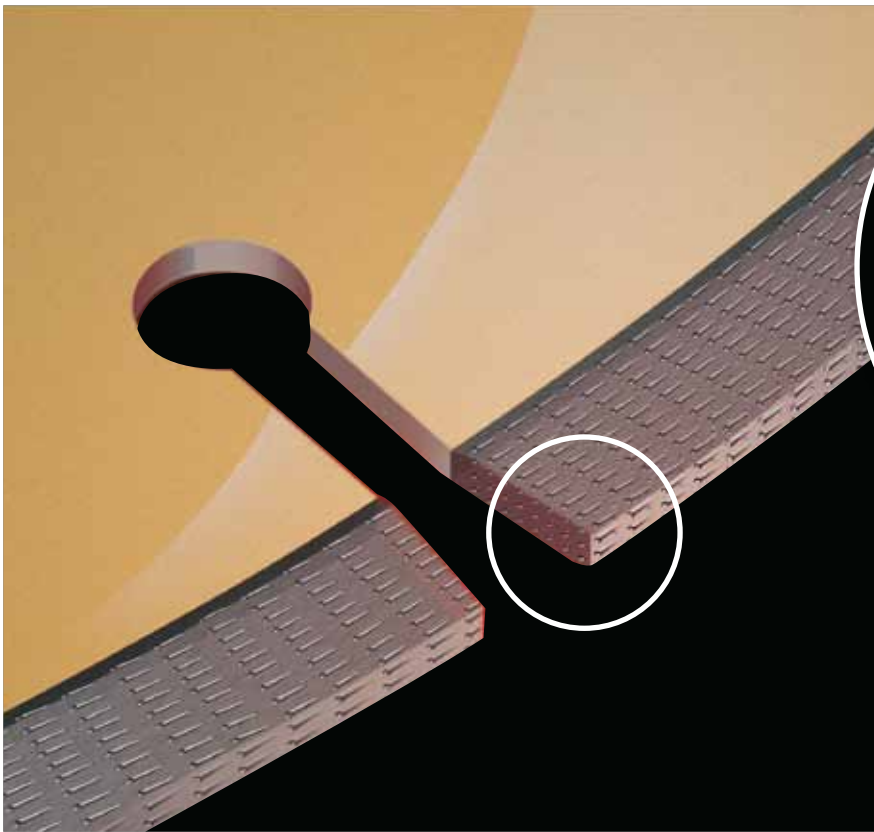

DURATA
+20%
+50%
LIFE

VELOCITA'
+30%
SPEED

RENDIMENTO
+100%
PERFORMANCE



Test eseguiti su dischi diamantati Brevetti Montolit - Tests made on Brevetti Montolit diamond tools - Tests effectués sur des disques diamantés Brevetti Montolit - An Diamant-Schleifscheiben von Brevetti Montolit vorgenommene Tests

 La resa (durata nel tempo) degli utensili diamantati tradizionali é di norma inversamente proporzionale alla velocità di taglio, grazie al sistema DNA si é raggiunto un evidente incremento della durata +20% /+50 %. Contemporaneamente si è ottenuto un notevole aumento della velocità di taglio, mediamente + 30%. Il vantaggio sostanziale però é rappresentato dalla costanza delle prestazioni.

 *With the old order of Diamond Tools it is recognised that the life of the tool is inversely proportional to its' cutting speed, however with DNA Montolit products, the life is increased significantly, depending on the material being cut, by up to 50%. At the same time reducing the cutting time by at least 30%. Most of all, however, perhaps the most important characteristic with DNA Montolit Technology is CONSISTENCY OF PERFORMANCE!*

 Le rendement (durée dans le temps) des outils diamantés traditionnels est en général inversement proportionnel à la vitesse de coupe ; grâce au système DNA, on a atteint une augmentation évidente de la durée de +20 % / +50 %. Dans le même temps, une augmentation importante de la vitesse de coupe est obtenue, en moyenne +30 %. L'avantage principal est cependant représenté par la constance des prestations.

 *Die Ergiebigkeit (Haltbarkeit) der herkömmlichen diamantbeschichteten Werkzeuge ist gewöhnlich zur Schnittgeschwindigkeit umgekehrt proportional, dank des DNA-Systems wurde eine ersichtliche Steigerung der Haltbarkeit (+20% - +50%) erreicht. Gleichzeitig wurde eine bemerkenswerte Steigerung der Schnittgeschwindigkeit, durchschnittlich + 30% erzielt. Den wesentlichen Vorteil stellt jedoch die Beständigkeit der Leistungen dar.*

DNA EVO3 • CONTINUOUS RIM

GOLD LINE
"HIGH TECHNOLOGY"

NEW
"SANDWICH TECH"
++ VELOCITA'
SPEED
++ FINITURA
PERFECT CUT

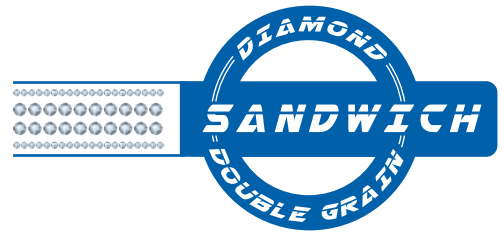

CX		Gres Porcellanato/Ceramica delicata/Marmo/Granito Porcelain Stoneware/Soft Ceramic/Marble/Granite Grès Emailé et Delicat/Marbre/Granite Feinsteinzeug/Empfindliche Keramikteile/Marmor/Granit				
Art.	Ø				€	
	mm	inch	mm	mm		
CX250	250	10	30/25,4	2,0	128,00	
CX300	300	12	30/25,4	2,2	149,00	
CX350	350	14	30/25,4	2,2	198,00	

DNA EVO3 • SEGMENTS

GOLD LINE
"HIGH TECHNOLOGY"



SCX		Gres Porcellanato/Ceramica "Pro"/Granito Porcelain Stoneware/Ceramic "Pro"/Granite Grès Vitrifié/Céramique "Pro"/Granit Feinsteinzeug/Keramikfliesen "Pro"/Granit				
Art.	Ø				€	
	mm	inch	mm	mm		
SCX180	180	7	25,4/22,2	2,0	122,00	
SCX200	200	8	30/25,4	2,0	126,00	
SCX230	230	9	30/25,4	2,2	141,00	
SCX250	250	10	30/25,4	2,2	158,00	
SCX300	300	12	30/25,4	2,4	179,00	
SCX350	350	14	30/25,4	2,4	235,00	
SCX400	400	16	60/50	3,2	328,00	

DNA EVO3 • SEGMENTS

GOLD LINE
"HIGH TECHNOLOGY"

NEW SPECIAL
2,5 cm
Grès Porcellanato



SCXS-T SILENT-TOP		Gres Porcellanato/Gres Porcellanato alto spessore/Ceramica dura/Granito Porcelain Stoneware/ Porcelain stoneware high thickness/ Hard ceramic/Granite Grès Vitrifié/ Grès cérame à haute épaisseur /Céramique Compacte/Granit Feinsteinzeug/ Feinsteinzeug -Hoch Dicke/Harter Keramikfliesen/Granit				
Art.	Ø				€	
	mm	inch	mm	mm		
SCXS-T200	200	8	30/25,4	2,0	155,00	
SCXS-T250	250	10	30/25,4	2,2	190,00	
SCXS-T300	300	12	30/25,4	2,4	211,00	
SCXS-T350	350	14	30/25,4	2,4	278,00	
SCXS-T400	400	16	60/50	3,2	374,00	

GOLD LINE
"HIGH TECHNOLOGY"

NEW
TOP QUALITY



CGX FRECCIA ORO	Gres Porcellanato/Ceramica Dura Porcelain Stoneware/Hard Ceramic Grès Vitrifié/Céramique Compacte Feinsteinzeug/Harter Keramikfliesen					
Art.						€
	mm	inch	mm	mm		
CGX100	100	4	22,2	1,3		45,00
CGX115	115	4,5	22,2	1,3		49,00
CGX125	125	5	22,2	1,3		55,00

DNA EVO3 • CONTINUOUS RIM

GOLD LINE
"HIGH TECHNOLOGY"

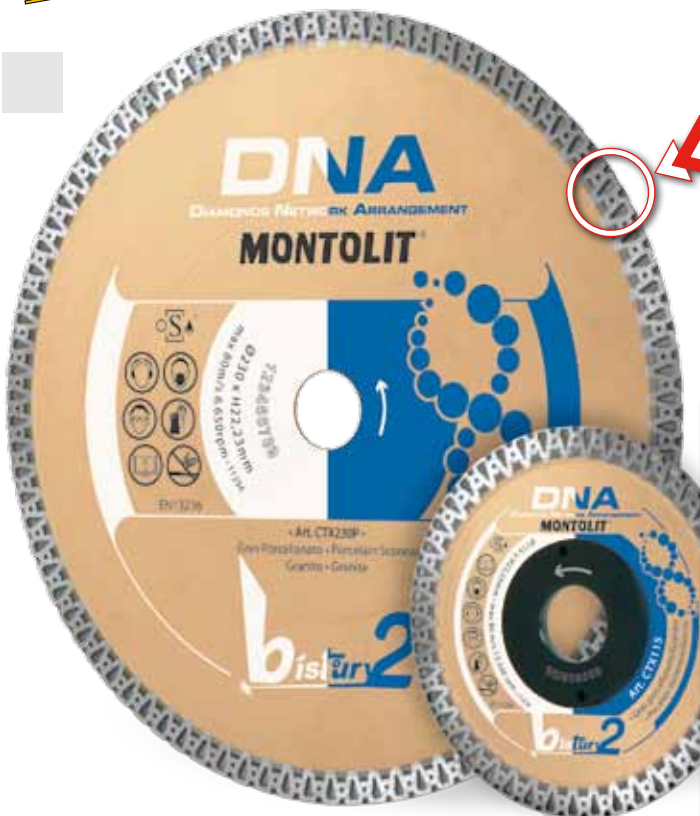

CTX

Gres Porcellanato/Granito/Edilizia
Porcelain Stoneware/Granite/Building Industry
Grès Vitrifié/Granit/Batiment
Feinsteinzeug/Granit/Bau Industrie



Art.	Ø		Ø		€
	mm	inch	mm	mm	
CTX100	100	4	22,2	1,3	44,00
CTX115	115	4,5	22,2	1,3	47,00
CTX125	125	5	22,2	1,3	58,00
CTX230P	230	9	22,2	2,0	99,00
CTX230F	230	9	22,2	2,0	104,00

DNA EVO3 • TURBO

GOLD LINE
"HIGH TECHNOLOGY"

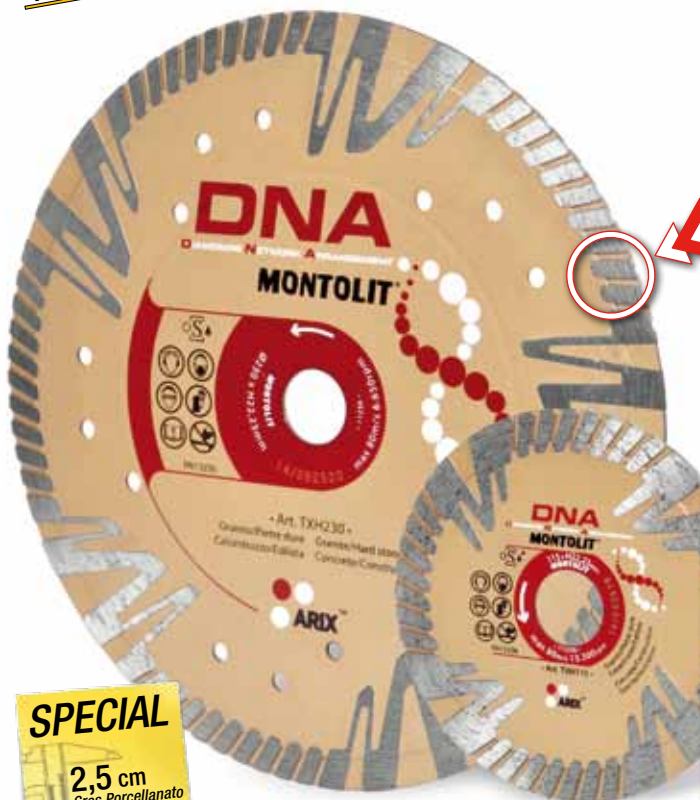

TXH

Granito/Pietre Dure/Calcestruzzo/Edilizia/Gres Porcellanato spessorato
Granite/Hard Stone/Concrete/Building Industry/Porcelain stoneware high thickness
Granit/Pierre Dure/Béton/Batiment/Grès cérame à haute épaisseur
Granit/Harter Stein/Beton/Bau Industrie/Feinsteinzeug -Hoch Dicke



Art.	Ø		Ø		€
	mm	inch	mm	mm	
TXH115*	115	4,5	22,2	2,4	58,00
TXH230	230	9	22,2	2,8	108,00

* A richiesta · On request · Sur demande · Auf Anfrage

FLANGIA
FLANGE
BRIDE
FLANSCH

M14



Art. 45194

€ 12,00

SPECIAL

2,5 cm
Gres Porcellanato

GOLD LINE
"HIGH TECHNOLOGY"

h
10 mm



LX	Calcestruzzo/Edilizia/Granito/Porfido/Pietre dure Concrete/Building Industry/Granite/Porphry/Hard Stone Béton/Batiment/Granit/Porphyre/Pierre Dure Beton/Bau Industrie/Granit/Porphyr/Harter Stein					
Art.						€
	mm	inch	mm	mm		
LX115	115	4,5	22,2	2,2		49,00
LX125	125	5	22,2	2,2		53,00
LX150	150	6	30/22,2	2,2		69,00
LX180	180	7	30/22,2	2,2		88,00
LX230	230	9	22,2	2,6		97,00

GOLD LINE
"HIGH TECHNOLOGY"

h
10 mm



LXS SILENT	Calcestruzzo/Edilizia/Granito/Porfido/Pietre dure Concrete/Building Industry/Granite/Porphry/Hard Stone Béton/Batiment/Granit/Porphyre/Pierre Dure Beton/Bau Industrie/Granit/Porphyr/Harter Stein					
Art.						€
	mm	inch	mm	mm		
LXS230	230	9	22,2	2,6		108,00

DNA EVO3 • LASER

GOLD LINE
"HIGH TECHNOLOGY"



LX	Calcestruzzo/Edilizia/Granito/Porfido/Pietre dure Concrete/Building Industry/Granite/Porphyr/Hard Stone Béton/Batiment/Granit/Porphyre/Pierre Dure Beton/Bau Industrie/Granit/Porphyr/Harter Stein				
Art.					€
	mm	inch	mm	mm	
LX250	250	10	30/25,4	2,6	145,00
LX300	300	12	30/25,4	3,2	210,00
LX350	350	14	30/25,4	3,2	272,00
LX400	400	16	30/25,4	3,2	316,00
LX600	600	24	30/25,4	4,0	428,00
LX650	650	26	30/25,4	4,0	657,00
LX720	720	29	30/25,4	4,0	762,00

DNA EVO3 • LASER

GOLD LINE
"HIGH TECHNOLOGY"



LXS SILENT	Calcestruzzo/Edilizia/Granito/Porfido/Pietre dure Concrete/Building Industry/Granite/Porphyr/Hard Stone Béton/Batiment/Granit/Porphyre/Pierre Dure Beton/Bau Industrie/Granit/Porphyr/Harter Stein				
Art.					€
	mm	inch	mm	mm	
LXS350	350	14	30/25,4	3,2	298,00

GOLD LINE
"HIGH TECHNOLOGY"

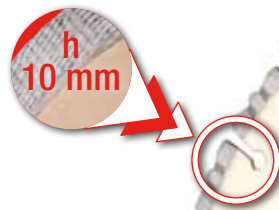

LXR	Calcestruzzo/Edilizia/Materiali abrasivi/Granito Concrete/Building Industry/Abrasive materials/Granite Béton/Batiment/Matériaux abrasifs/Granit Beton/Bau Industrie/Schleifmittel/Granit				
Art.					€
	mm	inch	mm	mm	
LXR300	300	12	30/25,4	3,2	210,00
LXR350	350	14	30/25,4	3,2	284,00
LXR400	400	16	30/25,4	3,2	318,00

GOLD LINE
"HIGH TECHNOLOGY"

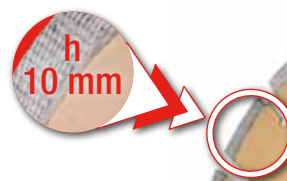

LXA	Calcestruzzo/Asfalto (Per macchine di bassa/media potenza - max 5kW) Concrete/Asphalt (For low power machines - max 5kW) Béton/Asphalte (Pour machines à faible puissance - max 5kW) Beton/Asphalt (Für Maschinen mit niedriger Leistung - max 5kW)				
Art.					€
	mm	inch	mm	mm	
LXA350	350	14	30/25,4	3,2	258,00
LXA400	400	16	30/25,4	3,2	314,00
LXA450	450	18	30/25,4	3,2	378,00

DNA EVO3 • LASER

GOLD LINE
"HIGH TECHNOLOGY"

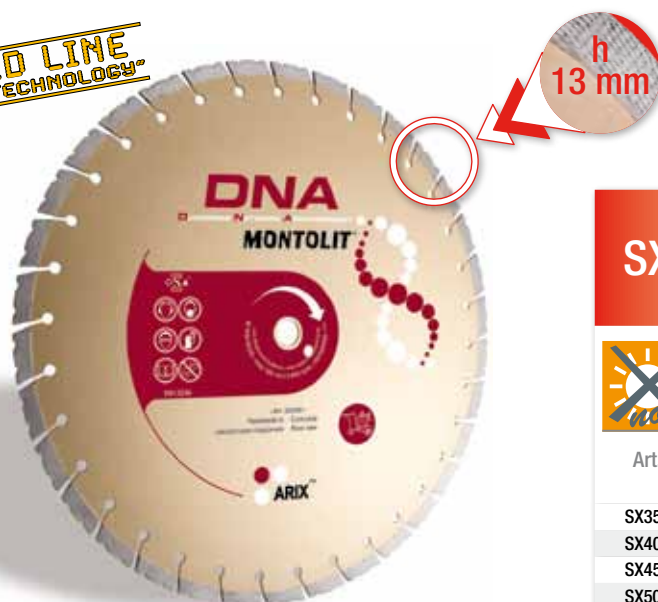

SX	Pavimenti in calcestruzzo stagionato <i>Concrete floor saw</i> Pavage en béton vieux <i>Straßendecke aus Beton Gelagert</i>					
Art.					€	
	mm	inch	mm	mm		
SX350	350	14	30/25,4	2,8	364,00	
SX400	400	16	30/25,4	3,2	466,00	
SX450	450	18	30/25,4	3,2	512,00	
SX500	500	20	30/25,4	4,0	588,00	

DNA EVO3 • LASER

GOLD LINE
"HIGH TECHNOLOGY"



SXF	Pavimenti in calcestruzzo fresco <i>Green-mixed concrete floor saw</i> Pavage en béton frais <i>Straßendecke aus Frischbeton</i>					
Art.					€	
	mm	inch	mm	mm		
SXF350	350	14	30/25,4	3,2	364,00	
SXF400	400	16	30/25,4	3,2	384,00	
SXF450	450	18	30/25,4	3,2	407,00	

DNA EVO3 • LASER

GOLD LINE
"HIGH TECHNOLOGY"



SXA	Asfalto <i>Asphalt</i> Asphalte <i>Asphalt</i>					
Art.					€	
	mm	inch	mm	mm		
SXA400	400	16	30/25,4	3,2	361,00	
SXA450	450	18	30/25,4	3,6	439,00	
SXA500	500	20	30/25,4	3,6	533,00	

GOLD LINE
"HIGH TECHNOLOGY"

Art.	∅		n°	h max		€
	mm	inch		mm	inch	
FX 32	32	1-1/4	4	450	128,00	
FX 36	36	1-7/16	4	450	129,00	
FX 42	42	1-5/8	5	450	136,00	
FX 47	47	1-7/8	5	450	154,00	
FX 52	52	2-1/16	5	450	160,00	
FX 62	62	2-7/16	6	450	177,00	
FX 82	82	3-1/4	8	450	228,00	
FX 92	92	3-5/8	8	450	245,00	
FX102	102	4	10	450	260,00	
FX112	112	4-7/16	11	450	282,00	
FX122	122	4-3/4	12	450	305,00	
FX132	132	5-3/16	13	450	336,00	
FX142	142	5-5/8	13	450	352,00	
FX152	152	6	14	450	381,00	
FX162	162	6-3/8	14	450	488,00	
FX182	182	7-3/16	17	450	546,00	
FX202	202	8	18	450	711,00	
FX225	225	8-7/8	18	450	814,00	
FX250	250	9-7/8	22	450	958,00	



GOLD LINE
"HIGH TECHNOLOGY"

Art.	∅		n°	h max		€
	mm	inch		mm	inch	
FUXL 52	52	2-1/16	3	300	128,00	
FUXL 62	62	2-7/16	3	300	156,00	
FUXL 68	68	2-11/16	4	300	157,00	
FUXL 82	82	3-1/4	4	300	169,00	
FUXL102	102	4	5	300	197,00	
FUXL112	112	4-7/16	5	300	214,00	
FUXL127	127	5	6	300	254,00	
FUXL162	162	6-3/8	8	300	370,00	



GOLD LINE
"HIGH TECHNOLOGY"



Art. 400FUT/FUX

Espositore in promozione, a richiesta, con l'acquisto minimo di 4 pcs.

Display free of charge, on request with a minimum purchase of 4 pcs.

Présentoir dans la promotion, sur demande, avec l'achat minimum de 4 pièces.

Aussteller in Förderung, auf Anfrage, mit dem Bestellwert von mindestens 4 Stück.



FUX		Calcestruzzo/Laterizio/Mattoni Abrasivi/Autobloccanti Concrete/Bricks/Abrasive Bricks and Self-blocking Béton/Briques/Briques Abrasifs et Autobloquants Beton/Mauerziegel/KalkSandstein und Betonstein					
Art.	Ø		h max		€		
	mm	inch	n°	mm			
FUX 32	32	1-1/4	M16	3	150	80,00	
FUX 36	36	1-7/16	M16	3	150	83,00	
FUX 42	42	1-5/8	M16	3	150	88,00	
FUX 47	47	1-7/8	M16	3	150	102,00	
FUX 52	52	2-1/16	M16	3	150	105,00	
FUX 57	57	2-1/4	M16	3	150	109,00	
FUX 62	62	2-7/16	M16	3	150	114,00	
FUX 68	68	2-11/16	M16	4	150	119,00	
FUX 82	82	3-1/4	M16	4	150	128,00	
FUX 92	92	3-5/8	M16	4	150	146,00	
FUX102	102	4	M16	5	150	158,00	
FUX112	112	4-7/16	M16	5	150	174,00	
FUX127	127	5	M16	6	150	198,00	
FUX132	132	5-3/16	M16	6	150	212,00	
FUX142	142	5-5/8	M16	7	150	220,00	
FUX152	152	6	M16	7	150	233,00	
FUX162	162	6-3/8	M16	8	150	262,00	
FUX182	182	7-3/16	M16	8	150	294,00	
FUX202	202	8	M16	9	150	316,00	

TURBO LASER



Art. 400FUT/FUX

Espositore in promozione, a richiesta, con l'acquisto minimo di 4 pcs.





























Display free of charge, on request with a minimum purchase of 4 pcs.

Présentoir dans la promotion, sur demande, avec l'achat minimum de 4 pièces.

Aussteller in Förderung, auf Anfrage, mit dem Bestellwert von mindestens 4 Stück.



FUT		Calcestruzzo/Laterizio/Mattoni Abrasivi/Autobloccanti Concrete/Bricks/Abrasive Bricks and Self-blocking Béton/Briques/Briques Abrasifs et Autobloquants Beton/Mauerziegel/KalkSandstein und Betonstein					
Art.	Ø		h max		€		
	mm	inch	n°	mm			
FUT 32	32	1-1/4	M16	3	150	74,00	
FUT 36	36	1-7/16	M16	3	150	76,00	
FUT 42	42	1-5/8	M16	3	150	80,00	
FUT 47	47	1-7/8	M16	3	150	84,00	
FUT 52	52	2-1/16	M16	3	150	87,00	
FUT 57	57	2-1/4	M16	3	150	89,00	
FUT 62	62	2-7/16	M16	3	150	94,00	
FUT 68	68	2-11/16	M16	4	150	99,00	
FUT 82	82	3-1/4	M16	4	150	106,00	
FUT 92	92	3-5/8	M16	4	150	118,00	
FUT102	102	4	M16	5	150	126,00	
FUT112	112	4-7/16	M16	5	150	136,00	
FUT127	127	5	M16	6	150	156,00	
FUT132	132	5-3/16	M16	6	150	164,00	
FUT152	152	6	M16	7	150	179,00	
FUT162	162	6-3/8	M16	8	150	206,00	
FUT182	182	7-3/16	M16	8	150	230,00	
FUT200	200	7-7/8	M16	9	150	244,00	
FUT210	210	8-1/4	M16	9	150	278,00	
FUT225	225	8-7/8	M16	10	150	340,00	

Art.		mm	inch	€	
AM16F	G 1/2" →  M16			26,00	
AM16M	G 1/2" →  M16			26,00	
AM16F18	M18 →  M16			26,00	
NEW M-AU80	∅ 12mm →  →  M16	80	3-1/4	24,00	
NEW M-AU180		180	7	32,00	
NEW M-AU280	NICHEL-CROMO-MOLIBDENO	280	11	36,00	
NEW M-AS100	SDS PLUS →  →  M16	100	4	39,00	
NEW M-AS180		180	7	44,00	
NEW M-AS280	NICHEL-CROMO-MOLIBDENO	280	11	48,00	
NEW M-ASMAX	SDS MAX →  →  M16 NICHEL-CROMO-MOLIBDENO	130	5-1/8	78,00	
NEW M-PR250	M16 →  → M16 NICHEL-CROMO-MOLIBDENO	250	10	44,00	
NEW M-PC240	∅ 12mm →  →  M16 NICHEL-CROMO-MOLIBDENO	240	9-3/8	26,00	
PCFUXL	 →  M16 NICHEL-CROMO-MOLIBDENO	400	16	108,00	
PCFX	 →  M16 NICHEL-CROMO-MOLIBDENO	550	21-1/2	94,00	
MT-EACC-0022	1" 1/4 →  → 1" 1/4	250	10	74,00	
MT-EACC-0023		500	20	124,00	

mm	inch	N° DI GIRI RPM	POTENZA CONSIGLIATA SUGGESTED POWER		VELOCITÀ CONSIGLIATA RECOMMENDED SPEED
			W min	W max	
32	1-1/4	800 ÷ 1.800	1.200	1.800	MATERIALE TENERO SOFT MATERIAL 3-4 m/s
36	1-7/16	700 ÷ 1.700	1.200	1.800	
42	1-5/8	700 ÷ 1.700	1.200	1.800	
47	1-7/8	600 ÷ 1.500	1.200	1.800	
52	2-1/16	500 ÷ 1.300	1.200	1.800	
57	2-1/4	450 ÷ 1.200	1.200	1.800	
62	2-7/16	450 ÷ 1.100	1.200	1.800	
68	2-11/16	400 ÷ 900	1.200	2.200	
82	3-1/4	350 ÷ 800	1.200	2.200	
92	3-5/8	320 ÷ 720	1.200	2.200	
102	4-1/32	280 ÷ 650	1.200	2.200	
112	4-3/8	250 ÷ 600	1.800	2.500	
122	4-13/16	230 ÷ 550	1.800	2.500	
127	5	230 ÷ 550	1.800	2.500	
132	5-3/16	230 ÷ 550	1.800	2.500	MATERIALE DURO HARD MATERIAL 1,5-2 m/s
152	6	200 ÷ 500	1.800	2.500	
162	6-3/8	180 ÷ 450	1.800	2.500	
202	7-15/16	150 ÷ 380	2.000	3.300	
225	8-7/8	150 ÷ 380	2.000	3.300	
250	9-7/8	150 ÷ 380	2.000	3.300	

CERMONT • CONTINUOUS RIM

BLU LINE
"UNIVERSAL"



CSE EVOLUTION	Ceramica/Gres Porcellanato Ceramic/Porcelain Stoneware Céramique/Grès Vitrifié Keramikfliesen/Feinsteinzeug				
Art.					€
	mm	inch	mm	mm	
CSE115	115	4,5	22,2	1,6	26,00
CSE230P	230	9	22,2	2,0	79,00
CSE230F	230	9	22,2	2,0	84,00

CERMONT • CONTINUOUS RIM

RED LINE
"PROFESSIONAL"



CG PROGRES	Gres Porcellanato/Ceramica Dura Porcelain Stoneware/Hard Ceramic Grès Vitrifié/Céramique Compacte Feinsteinzeug/Harter Keramikfliesen				
Art.					€
	mm	inch	mm	mm	
CG100	100	4	22,2	1,4	43,00
CG115	115	4,5	22,2	1,4	47,00
CG125	125	5	22,2	1,4	53,00
CG230	230	9	22,2	2,0	96,00

CONTINUOUS RIM • CERMONT

SILVER LINE
"TOP"

h
10 mm



MASSIMA FINITURA
VELOCITÀ RIDOTTA.
NON FORZARE!!
CLEAN CUT - LOW SPEED
DON'T FORCE
WHILE CUTTING

CM
MOSAIC

Mosaico vetroso e/o in pietra naturale/Ceramica sottile e delicata
Naturalstone and glass mosaic/Slim and Soft Ceramic
Mosaïque en pâte de verre et en pierre naturelle/Grès Emailé mince et délicat
Glas- und Natursteinmosaik/Schlank und Empfindliche Keramikteile



Art.	Ø				€
	mm	inch	mm	mm	
CM100	100	4	22,2	1,2	42,00
CM115	115	4,5	22,2	1,2	44,00
CM125	125	5	22,2	1,2	46,00

"SQUADRO"
art. TCS85 • Ø 85 mm



CONTINUOUS RIM • TURMONT

RED LINE
"PROFESSIONAL"

TCS-R

Gres Porcellanato/Ceramica Dura
Porcelain Stoneware/Hard Ceramic
Grès Vitrifié/Céramique Compacte
Feinsteinzeug/Harter Keramikfliesen



Art.	mm	inch	mm	mm	€
TCS85	85	3-3/8	22,2	1,0	29,00
TCS100R	100	4	22,2	1,4	38,00
TCS115R	115	4,5	22,2	1,4	39,00
TCS125R	125	5	22,2	1,4	42,00
NEW TCS150MFL	150	6	30/22,2	1,4	68,00
TCS180R	180	7	25,4/22,2	1,6	73,00
TCS200R	200	8	30/25,4	1,6	84,00
TCS230F	230	9	22,2	1,6	94,00
TCS250R	250	10	30/25,4	1,65	122,00
TCS300R	300	12	30/25,4	1,8	165,00
TCS350R	350	14	30/25,4	2,0	193,00



ULTRASOTTILE
RINFORZATO
REINFORCED
ULTRATHIN

CERMONT • CONTINUOUS RIM

RED LINE
"PROFESSIONAL"

h
10 mm



MASSIMA
VELOCITÀ
MAX SPEED

CPH XAMURAY	Ceramica/Gres Porcellanato/Marmo/Granito Ceramic/Porcelain Stoneware/Marble/Granite Céramique/Grès Vitrifié/Marbre/Granit Keramikfliesen/Feinsteinzeug/Marmor/Granit					
Art.	Ø					€
	mm	inch	mm	mm		
CPH180	180	7	25,4/22,2	1,6		62,00
CPH200	200	8	30/25,4	1,6		74,00
CPH230	230	9	30/25,4	1,6		84,00
CPH250	250	10	30/25,4	1,65		112,00
CPH300	300	12	30/25,4	2,0		137,00
CPH350	350	14	30/25,4	2,2		178,00

CERMONT • CONTINUOUS RIM

RED LINE
"PROFESSIONAL"

h
10 mm



MASSIMA FINITURA
VELOCITÀ RIDOTTA.
NON FORZARE!!
CLEAN CUT - LOW SPEED
DON'T FORCE
WHILE CUTTING

CPF PERFETTO	Gres Porcellanato/Ceramica delicata/Vetro/Marmo/Granito Porcelain Stoneware/Soft Ceramic/Glass/Marble/Granite Grès Emailé et Delicat/Verre/Marbre/Granite Feinsteinzeug/Empfindliche Keramikteile/Glas/Marmor/Granit					
Art.	Ø					€
	mm	inch	mm	mm		
CPF180	180	7	25,4/22,2	2,0		78,00
CPF200	200	8	30/25,4	2,0		88,00
CPF230	230	9	30/25,4	2,0		106,00
CPF250	250	10	30/25,4	2,0		128,00
CPF300	300	12	30/25,4	2,2		148,00
CPF350	350	14	30/25,4	2,2		196,00

CERMONT • CONTINUOUS RIM

SILVER LINE
"TOP"

special
edge
shape



MASSIMA FINITURA
VELOCITÀ RIDOTTA.
NON FORZARE!!
CLEAN CUT - LOW SPEED
DON'T FORCE
WHILE CUTTING

CPV	Piastrille in vetro Glass tiles Carreaux en verre Glastfliesen					
Art.	Ø					€
	mm	inch	mm	mm		
CPV100	100	4	22,2	1,4		108,00
CPV180	180	7	25,4/22,2	1,6		196,00
CPV200	200	8	30/25,4	1,6		206,00
CPV250	250	10	30/25,4	1,9		240,00
CPV300	300	12	30/25,4	2,1		274,00

SILVER LINE
"TOP"



LTF
BRACCIO DI FERRO

Calcestruzzo Fortemente Armato/Granito/Porfido/Pietre Dure/Ferro
Reinforced Concrete/Granite/Porphyry/Hard Stone/Iron
Béton Armé/Granit/Porphyre/Pierre Dure/Fer
Stahlbeton/Granit/Porphyr/Harter Stein/Eisen

Art. €

Art.	mm	inch	mm	mm	€
LTF230P	230	9	22,2	2,4	126,00

* A richiesta - On request - Sur demande - Auf Anfrage

Art. 45194 FLANGIA
 FLANGE
 BRIDE
 FLANSCH

€ 12,00

M14

ED

Marmo/Fibre di vetro/Vetroresina
Marble/Fiberglass
Marbre/Fibres de Verre
Marmor/Fiberglas

Art. €

Art.	mm	inch	mm	€
ED115*	115	4,5	22,2	46,00
ED125*	125	5	22,2	50,00
ED180	180	7	22,2	72,00
ED200	200	8	22,2	77,00
ED230P	230	9	22,2	106,00
ED250	250	10	30/25,4	138,00
ED300	300	12	30/25,4	154,00
ED350	350	14	30/25,4	176,00

ELECTROPLATED

SILVER LINE
"TOP"



SEGMENTS • SECTORMONT

SILVER LINE
"TOP"



SR

Refrattario/Materiali Abrasivi/Granito/Porfido
Refractory/Abrasive Materials/Granite/Porphyry
Réfractaire/Matériaux Abrasifs/Granit/Porphyre
Schamottestein/Schleifmittel/Granit/Porphyr

Art. €

Art.	mm	inch	mm	mm	€
SR30021	300	12	30/25,4	3,0	236,00
SR35025	350	14	30/25,4	3,2	248,00
SR40028	400	16	30/25,4	3,5	312,00
SR45032	450	18	30/25,4	4,0	328,00
SR50030	500	20	30/25,4	4,5	398,00
SR55032*	550	22	30/25,4	5,0	446,00
SR60036	600	24	30/25,4	5,0	532,00
SR65038*	650	26	30/25,4	5,0	606,00



* A richiesta • On request • Sur demande • Auf Anfrage

TURMONT • TURBO

BLU LINE
"UNIVERSAL"



h
10 mm

Art.	Ø		Ø		€
	mm	inch	mm	mm	
TEH115	115	4,5	22,2	2,2	30,00
TEH125	125	5	22,2	2,2	37,00
TEH230P	230	9	22,2	2,4	63,00
TEH230F	230	9	22,2	2,4	68,00

TURMONT • TURBO

RED LINE
"PROFESSIONAL"



h
10 mm

* A richiesta · On request · Sur demande · Auf Anfrage

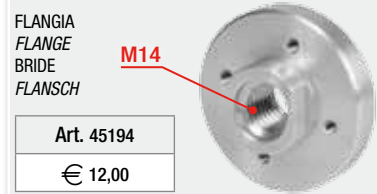

Art.	Ø		Ø		€
	mm	inch	mm	mm	
TBH115*	115	4,5	22,2	2,4	39,00
TBH125*	125	5	22,2	2,4	46,00
TBH150	150	6	22,2	2,4	58,00
TBH180	180	7	22,2	2,4	64,00
TBH200	200	8	30/25,4	2,4	68,00
TBH230P	230	9	22,2	2,4	77,00
TBH230F	230	9	22,2	2,4	82,00
TBH250	250	10	30/25,4	2,8	112,00
TBH300	300	12	30/25,4	2,8	164,00
TBH350	350	14	30/25,4	3,3	220,00

BLU LINE
"UNIVERSAL"

h
10 mm



LEH	Edilizia Building Industry Batiment Bau Industrie				
Art.	Ø		Ø		€
	mm	inch	mm	mm	
LEH115	115	4,5	22,2	2,2	29,00
LEH125	125	5	22,2	2,2	36,00
LEH230P	230	9	22,2	2,4	62,00
LEH30018	300	12	30/25,4	2,8	116,00
LEH35021	350	14	30/25,4	3,2	148,00
LEH40024	400	16	30/25,4	3,4	172,00
LEH45026	450	18	30/25,4	3,6	198,00
LEH50029	500	20	30/25,4	3,6	238,00
LEH55032	550	22	30/25,4	4,0	268,00
LEH60035	600	24	30/25,4	4,0	328,00
LEH65037	650	26	30/25,4	4,0	358,00
LEH72040	720	29	30/25,4	4,0	488,00
LEH75042	750	30	30/25,4	4,0	526,00

* A richiesta · On request · Sur demande · Auf Anfrage

FLANGIA
FLANGE
BRIDE
FLANSCH

M14

Art. 45194
€ 12,00

RED LINE
"PROFESSIONAL"

h
10 mm



LBH	Calcestruzzo/Granito/Porfido/Pietre dure Concrete/Granite/Porphyry/Hard Stone Béton/Granit/Porphyre/Pierre Dure Beton/Granit/Porphy/Harter Stein				
Art.	Ø		Ø		€
	mm	inch	mm	mm	
LBH115 *	115	4,5	22,2	2,0	53,00
LBH125 *	125	5	22,2	2,2	59,00
LBH150	150	6	30/22,2	2,4	74,00
LBH160	160	6-5/16	22,2	2,4	89,00
LBH180	180	7	30/22,2	2,4	84,00
LBH190	190	7,5	22,2	2,4	102,00
LBH200	200	8	30/25,4	2,4	88,00
LBH230P	230	9	22,2	2,4	98,00
LBH250	250	10	30/25,4	2,4	113,00
LBH30021	300	12	30/25,4	2,8	144,00
LBH35025	350	14	30/25,4	3,2	184,00
LBH40028	400	16	30/25,4	3,2	207,00
LBH45032	450	18	30/25,4	3,4	248,00

CERMONT • CONTINUOUS RIM

GREEN LINE
"BASIC"



* A richiesta · On request · Sur demande · Auf Anfrage

FLANGIA
FLANGE
BRIDE
FLANSCH

M14

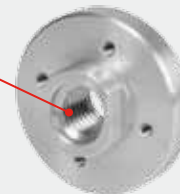

Art. 45194

€ 12,00

CZ

Gres Porcellanato/Ceramica
Porcelain Stoneware/Ceramic
Grès Vitrifié/Céramique
Feinsteinzeug/Keramikfliesen

MIN. 30 PCS



Art.	Ø		Ø		€
	mm	inch	mm	mm	
CZ100	100	4	22,2/15,8	1,4	17,00
CZ115 *	115	4,5	22,2	1,4	18,00
CZ125 *	125	5	22,2	1,4	21,00
CZ180	180	7	22,2	1,6	38,00

TURMONT • CONTINUOUS RIM

GREEN LINE
"BASIC"



TCS-E

Ceramica/Gres Porcellanato
Ceramic/Porcelain Stoneware
Céramique/Grès Vitrifié
Keramikfliesen/Feinsteinzeug

MIN. 30 PCS

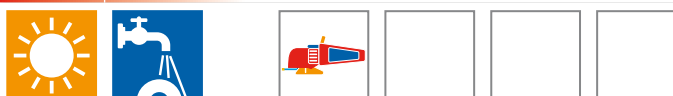

Art.	Ø		Ø		€
	mm	inch	mm	mm	
TCS100E	100	4	22,2/15,8	1,4	19,00
TCS115E	115	4,5	22,2	1,4	20,00
TCS125E	125	5	22,2	1,4	22,00

TURMONT • TURBO

GREEN LINE
"BASIC"



TZ

Edilizia
Building Industry
Batiment
Bau Industrie

MIN. 30 PCS

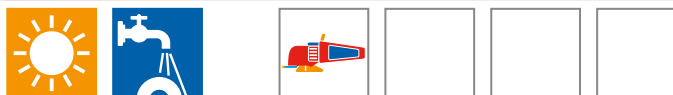

Art.	Ø		Ø		€
	mm	inch	mm	mm	
TZ115	115	4,5	22,2	2,0	20,00
TZ230P	230	9	22,2	2,6	39,00
TZ230F	230	9	22,2	2,6	44,00



**GUIDA ALLA SCELTA DI FRESE E PUNTE DIAMANTATE • SELECTION GUIDE OF DIAMOND CORE-BITS
GUIDE POUR LA SÉLECTION DES FRAISES DIAMANTEES • ANLEITUNG ZUR AUSWAHL DER DIAMANTKRONEN**

		MODEL	UTILIZZO / USE
mm	inch		
5	3/16	FAJ / FTJ / MU	TASSELLI / WALL PLUGS
6	1/4	FAJ / FS / FTJ / MU	TASSELLI / WALL PLUGS
8	5/16	FAJ / FS / FTJ / MU	TASSELLI / WALL PLUGS
10	3/8	FAJ / FS / FT / FTJ / MU	TASSELLI / WALL PLUGS
12	1/2	FAJ / FS / FTJ / MU	TASSELLI, FERMAPORTA / WALL PLUGS, DOOR STOPPER
14	9/16	FS / MU	TASSELLI, FERMAPORTA / WALL PLUGS, DOOR STOPPER
15	5/8	FT	TUBO 1/4", TASSELLI, FERMAPORTA / 1/4" TUBE, WALL PLUGS, DOOR STOPPER
16	5/8	FS	INCASSO PORTE BLINDATE / RECESS ARMORED DOORS
18	11/16	FS	TUBO 3/8" IN RAME PER GAS, ACQUA / 3/8" COPPER TUBE FOR GAS, WATER
20	3/4	FA / FS / FT / FT-S	TUBO 3/8" IN RAME PER GAS, ACQUA / 3/8" COPPER TUBE FOR GAS, WATER
25	1	FS	TUBO 1/2" ACQUA, RUBINETTI, RISCALDAMENTO, CIVILE / 1/2" TUBE FUCETS SYSTEM, HEATING SYSTEM
27	1-1/16	FA / FS / FT / FT-S	TUBO 1/2" ACQUA, RUBINETTI, RISCALDAMENTO, CIVILE / 1/2" TUBE FUCETS SYSTEM, HEATING SYSTEM
30	1-3/16	FA / FS	TUBO 3/4" ACQUA, RUBINETTI, RISCALDAMENTO, CIVILE / 3/4" TUBE FUCETS SYSTEM, HEATING SYSTEM
32	1-1/4	FA	TUBO 3/4" ACQUA, RUBINETTI, RISCALDAMENTO, CIVILE / 3/4" TUBE FUCETS SYSTEM, HEATING SYSTEM
35	1-3/8	FA / FS / FT / FT-S	TUBO 1" FERRO O PVC PER ACQUA, GAS, INDUSTRIALE / 1" IRON OR PVC TUBE FOR WATER, GAS, INDUSTRIAL USE
40	1-1/2	FA / FS / FT / FT-S	TUBO 1" FERRO O PVC PER ACQUA, GAS, INDUSTRIALE / 1" IRON OR PVC TUBE FOR WATER, GAS, INDUSTRIAL USE
45	1-3/4	FA / FS	TUBO 1-1/4" SCARICO LAVELLO, LAVANDINO, LAVASTOVIGLIE / 1-1/4" DRAINAGE SYSTEM FOR BATHROOM, KITCHEN, SINK
50	2	FA / FS / FT / FT-S	TUBO 1-1/4" SCARICO LAVELLO, LAVANDINO, LAVASTOVIGLIE / 1-1/4" DRAINAGE SYSTEM FOR BATHROOM, KITCHEN, SINK
55	2-3/16	FA / FS	TUBO 1-1/2" SCARICO LAVATRICE / 1-1/2" WASTE PIPE FOR WASHING MACHINE, DRAIN SYSTEM
60	2-3/8	FA / FS / FT / FT-S	TUBO 1-1/2" SCARICO LAVATRICE / 1-1/2" WASTE PIPE FOR WASHING MACHINE, DRAIN SYSTEM
65	2-1/2	FA / FS / FT / FT-S	TUBO 1-1/2" SCARICO LAVATRICE / 1-1/2" WASTE PIPE FOR WASHING MACHINE, DRAIN SYSTEM
68	2-11/16	FS	FARETTI AD INCASSO, TUBO 2" / RECESSED SPOTLIGHT, 2" TUBE
70	2-3/4	FA / FS	TUBO 2" SCARICO LAVATRICI INDUSTRIALI, RACCORDI PVC, PISCINE / 2" WASTE PIPE FOR WASHING MACHINE, PVC CONNECTION PIPE AND SWIMMINGPOOL
75	3	FA / FS / FT	TUBO 2" O 2-1/2" SCARICO LAVATRICI INDUSTRIALI, RACCORDI PVC, PISCINE / 2" O 2-1/2" WASTE PIPE FOR WASHING MACHINE, PVC CONNECTION PIPE AND SWIMMINGPOOL
100	4	FA / FS / FT	TUBO 3" SCARICO WC, PRESA ARIA CUCINA - CALDAIA / 3" FLUSHING SYSTEM PIPE FOR WC, VENTILATION OUTLET FOR KITCHEN-BOILER
120	4-3/4	FA / FS / FT	PRESA ARIA CUCINA - CALDAIA / VENTILATION OUTLET FOR KITCHEN-BOILER

MONDRILLO • FORATURA A SECCO

DRY DRILLING • PERÇAGE A SEC • TROCKENBOHRUNG



Art. FAJVA-N



**NEW
MODEL**

**FAJ
JUNIOR**

Gres Porcellanato/Ceramica/Monocottura/Granito/Marmo/Vetro
Porcelain Stoneware/Ceramic/Single Fired Tile/Granite/Marble/Glass
Grés Vitrifié/Cèramique/Monocuisson/Granit/Marbre/Verre
Feinsteinzeug/Steinzeug (Keramikfliesen)/Marmor/Granit/Glas



Art.	Ø		h max		€
	mm	inch	mm	mm	
FAJ05	5	3/16	10	40	22,00
FAJ06	6	1/4	10	40	22,00
FAJ08	8	5/16	10	40	22,00
FAJ10	10	3/8	10	40	22,00
FAJ12	12	1/2	10	40	26,00
FAJVA-N	Box + FAJ 05/06/08/10/12				104,00
FAJ6VA	Box + 5 art.FAJ06				100,00
FAJ8VA	Box + 5 art.FAJ08				100,00

MONDRILLO Performer



Art.	BOX	€
M-Performer	S/6	14,00

FORATURA A SECCO • KILLER GRES

DRY DRILLING • PERÇAGE A SEC • TROCKENBOHRUNG



FTJ JUNIOR	Gres Porcellanato/Ceramica/Monocottura/Granito Porcelain Stoneware/Ceramic/Single Fired Tile/Granite Grès Vitrifié/Cèramique/Monocuisson/Granit Feinsteinzeug/Steinzeug (Keramikfliesen)/Granit				
Art.	Ø		h max	€	
	mm	inch	mm	mm	
FTJ05	5	3/16	10	30	36,00
FTJ06	6	1/4	10	30	38,00
FTJ08	8	5/16	10	30	39,00
FTJ10	10	3/8	10	30	41,00
FTJ12	12	1/2	10	30	52,00
FTJVA-N	Box + FTJ 05/06/08/10/12				193,00

Art. FTJVA-N



FLUIDO REFRIGERANTE PER LA RESA OTTIMALE DELLE PUNTE DIAMANTATE PER I DIAMETRI FINO A 12MM.

COOLING FLUID FOR OPTIMAL PERFORMANCE OF DIAMOND CORE BITS (DIAMETERS UPTO 12MM).

FLUIDE RÉFRIGÉRANT POUR LE RENDEMENT OPTIMAL DE L'OUTIL DIAMANTÉ (DIAMÈTRES JUSQU'À 12MM).

KÜHLPASTE AUF HARZBASIS FÜR DIE OPTIMALE LEISTUNG VON DIAMANT-BOHRKRONEN BIS 12 MM DURCHMESSER.



MONDRILLO Performer

Art.	BOX	€
M-Performer	S/6	14,00



MONDRILLO • FORATURA A SECCO

DRY DRILLING • PERÇAGE A SEC • TROCKENBOHRUNG



MONDRILLO PERFORMER

++ LIFE TIME ++ SPEED
(max Ø 12 mm)

Art. M-Performer

€ 14,00

(pag. 68)



FS
WAVE

Gres Porcellanato/Ceramica dura/Granito/Marmo
Porcelain Stoneware/Hard ceramic/Granite/Marble
Grès Vitrifié/Céramique compacte/Granit/Marbre
Feinsteinzeug/Harter Keramikfliesen/Marmor/Granit



Art.	Ø		h max	€
	mm	inch		
FS 6	6	1/4	M14 35	48,00
FS 8	8	5/16	M14 35	49,00
FS 10	10	3/8	M14 35	50,00
FS 12	12	1/2	M14 35	54,00
FS 14	14	9/16	M14 35	58,00
FS 16	16	5/8	M14 35	62,00
FS 18	18	11/16	M14 35	64,00
FS 20	20	3/4	M14 35	68,00
FS 25	25	1	M14 35	79,00
FS 27	27	1-1/16	M14 35	85,00
FS 30	30	1-3/16	M14 35	92,00
FS 35	35	1-3/8	M14 35	102,00
FS 40	40	1-1/2	M14 35	112,00
FS 45	45	1-3/4	M14 35	120,00
FS 50	50	2	M14 35	128,00
FS 55	55	2-3/16	M14 35	143,00
FS 60	60	2-3/8	M14 35	158,00
FS 65	65	2-1/2	M14 35	165,00
FS 68	68	2-11/16	M14 35	169,00
FS 70	70	2-3/4	M14 35	172,00
FS 75	75	3	M14 35	178,00
FS100	100	4	M14 35	288,00
FS120	120	4-3/4	M14 35	348,00
AUFS	Raccordo per trapano - M14 / Adapter for drill - M14			16,00
400FS	Espositore in promozione, a richiesta, con l'acquisto minimo di 5 pcs.			

ART. AUFS

RACCORDO PER TRAPANO - M14
ADAPTER FOR DRILL - M14
ADAPTATEUR POUR PERCEUSE - M14
ADAPTER FÜR BOHRMASCHINE - M14



ART. 400FS

ESPOSITORE
DISPLAY
PRESENTOIRS
DISPLAY



MONDRILLO

FRESA DIAMANTATA UNIVERSALE PER ALLARGARE E SAGOMARE I FORI
 UNIVERSAL DIAMOND MILLING BIT FOR ENLARGING AND SHAPING HOLES
 FRAISE DIAMANTÉE UNIVERSELLE POUR AGRANDIR ET FAÇONNER UN TROU
 UNIVERSAL-DIAMANT-FRÄSFINGER FÜR DAS VERGRÖßERN UND AUSFORMEN VON LÖCHERN



FPU

Gres Porcellanato/Ceramica dura/Granito/Marmo
 Porcelain Stoneware/Hard ceramic/Granite/Marble
 Grés Vitrifié/Cèramique compacte/Granit/Marbre
 Feinsteinzeug/Harter Keramikfliesen/Marmor/Granit



NEW

Art.	Ø	inch	M	h max	€
FPU10	10	3/8	M14	50	88,00
FPU20	20	3/4	M14	50	92,00

FORATURA A SECCO • MONDRILLO

DRY DRILLING • PERÇAGE A SEC • TROCKENBOHRUNG



**FSB
BLACK**

Piastrelle in ceramica e pietra naturale
 Ceramic tiles and naturalstone
 Carreaux en céramique et pierre naturelle
 Keramikfliesen und Naturstein



Art.	Ø	inch	M	h max	€
FSB06	6	1/4	M14	35	38,00
FSB08	8	5/16	M14	35	39,00
FSB10	10	3/8	M14	35	40,00
FSB20	20	3/4	M14	35	48,00
FSB27	27	1-1/16	M14	35	62,00
FSB35	35	1-3/8	M14	35	74,00
FSB50	50	2	M14	35	92,00
FSBKIT	Box + FSB06 + FSB08 + FSB10				122,00
FSBKIT-IT	Box + FSB08 + FSB20 + FSB27 + FSB35 + FSB50				246,00
FSBKIT-ITFP	Box + FPU20 + FSB20 + FSB27 + FSB35 + FSB50				302,00
FSBKIT-H&T	Box + FSB27 + FSB35 + FAJ06 + FAJ08 + TCS85				204,00

NEW

KILLER GRES • FORATURA A SECCO

DRY DRILLING • PERÇAGE A SEC • TROCKENBOHRUNG



MONDRILLO PERFORMER

++ LIFE TIME ++ SPEED
(max Ø 12 mm)

Art. M-Performer

€ 14,00

(pag. 68)



ART. 400FT
ESPOSITORE
DISPLAY
PRESENTOIRS
DISPLAY



FT

Gres Porcellanato/Ceramica dura/Granito
Porcelain Stoneware/Hard ceramic/Granite
Grès Vitrifié/Cèramique compacte/Granit
Feinsteinzeug/Harter Keramikfliesen/Granit



Art.	Ø		h max		€
	mm	inch	mm	mm	
FT 6	6	1/4	10	45	62,00
FT 8	8	5/16	10	45	66,00
FT10	10	3/8	10	45	74,00
FT15	15	5/8	10	45	86,00
FT20	20	3/4	10	45	94,00
FT27	27	1-1/16	10	45	118,00
FT35	35	1-3/8	10	45	124,00
FT40	40	1-1/2	10	45	136,00
FT50	50	2	10	45	156,00
FT60	60	2-3/8	10	45	186,00
FT65	65	2-1/2	10	45	194,00
FT75	75	3	10	45	210,00
FT100	100	4	10	45	286,00
FT120	120	4-3/4	10	45	346,00

400FT

Espositore in promozione, a richiesta, con l'acquisto minimo di 5 pcs.

FORATURA A SECCO • KILLER GRES

DRY DRILLING • PERÇAGE A SEC • TROCKENBOHRUNG



!
UTENSILI
RAVVIVABILI
DRESSINGABLE
TOOLS

SPECIAL
2,5 cm
Grés Porcellanato

FT-S

Gres Porcellanato alto spessore/Ceramica dura/Granito
Porcelain Stoneware high thickness/Hard ceramic/Granite
Grés Vitrifié épaisseur haut/Céramique compacte/Granit
Feinsteinzeug-Hoch Dicke/Harter Keramikfliesen/Granit



Art.	Ø			h max	€
	mm	inch	mm	mm	
FT-S20	20	3/4	M14	50	114,00
FT-S27	27	1-1/16	M14	50	136,00
FT-S35	35	1-3/8	M14	50	142,00
FT-S40	40	1-1/2	M14	50	154,00
NEW FT-S43	43	1-11/16	M14	50	162,00
FT-S50	50	2	M14	50	178,00
NEW FT-S55	55	2-3/16	M14	50	188,00
FT-S60	60	2-3/8	M14	50	196,00
FT-S65	65	2-1/2	M14	50	204,00
NEW FT-S70	70	2-3/4	M14	50	216,00



VA	Gres Porcellanato/Ceramica/Monocottura/Granito/Marmo <i>Porcelain Stoneware/Ceramic/Single Fired Tile/Granite/Marble</i>		
	Grès Vitrifié/Céramique/Monocuisson/Granit/Marbre <i>Feinsteinzeug/Steinzeug (Keramikfliesen)/Marmor/Granit</i>		
Art.			€
VAF01	BOX + 88 + FA20 + FA27 + FA30 + FA35 + FA40 + FA45 + FA50 + FA65 + FA75 + FA100 + FA120		985,00
VAF01	BOX		52,00



Art. VAF01

ACCESSORI PER LA FORATURA AD ACQUA • *EQUIPMENT FOR WET DRILLING*
 OUTILLAGE POUR LE PERÇAGE A EAU • *AUSRÜSTUNG FÜR "NABBOHRUNG"*

	Art.		€
	AUFA	RACCORDO PER TRAPANO - M16 (x artt. FA/FAV) <i>ADAPTER FOR DRILL - M16 (x artt. FA/FAV)</i> ADAPTATEUR POUR PERCEUSE - M16 (x artt. FA/FAV) <i>ADAPTER FÜR BOHRMASCHINE - M16 (x artt. FA/FAV)</i>	16,00
	88	MANDRINO A PUNTA CENTRALE RETRAENTE (x artt. FA/FAV) <i>ARBOR WITH CENTRAL RETRACTABLE BIT (x artt. FA/FAV)</i> MANDRIN A POINTE CENTRAL ESCAMOTABLE (x artt. FA/FAV) <i>SPINDEL MIT GEFENDERTEM ZENTRIERBOHRER (x artt. FA/FAV)</i>	49,00
	CVG12	CONVOGLIATORE D'ACQUA COMPLETO DI TANICA <i>WATER FEED COMPLETE WITH JERRY</i> ASPERSEUR D'EAU AVEC RÉSERVOIR <i>WASSERLEITELEMENT KOMPLETT MIT KANISTER</i>	124,00
	89	RIDUZIONE M16 - G 1/2" <i>M16 - G 1/2" ADAPTER</i> ADAPTATEUR M16 - G 1/2" <i>ADAPTER M16 - G 1/2"</i>	18,00
	PS92	RACCORDO PORTAPUNTA PER MU (x artt. 915/916/CVG12) <i>DRILL - HOLDER CONNECTOR FOR MU (x artt. 915/916/CVG12)</i> RACCORD PORTE-FORET POUR MU (x artt. 915/916/CVG12) <i>BOHRHALTER MIT MADENSCHRAUBE FÜR MU (x artt. 915/916/CVG12)</i>	28,00
	VT120	VENTOSA DI CENTRAGGIO <i>SUCKER FOR HOLES CENTERING</i> VENTOUSE POUR LE CENTRAGE DES TROUS <i>SAUGNAPF FÜR BOHRZENTRIERUNG</i>	54,00
	VTKIT	VENTOSE PER FORATURA CON ACQUA (Ø 40mm + Ø 60mm) <i>SUCKERS FOR WATER DRILLING (Ø 40mm + Ø 60mm)</i> VENTOUSES POUR PERÇAGE AVEC EAU (Ø 40mm + Ø 60mm) <i>SAUGNÄPFE FÜR DIE BOHRUNG MIT WASSER (Ø 40mm + Ø 60mm)</i>	42,00

MONDRILLO

SCONTORNATORI DIAMANTATI • DIAMOND BEVEL PROFILES

BISEAUTAGE DIAMANTE • DIAMANT-PROFILFRÄSE



Gres Porcellanato/Granito/Marmo
Porcelain Stoneware/Granite/Marble
Grés Vitrifié/Granit/Marbre
Feinsteinzeug/Granit /Marmor

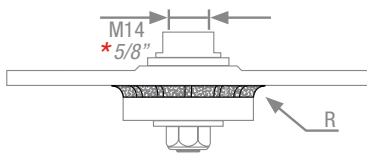

B

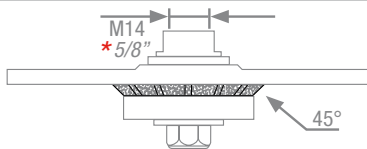

E

Art.

€

FPB03	"B" Profile - R = 3mm	186,00
FPB05	"B" Profile - R = 5mm	186,00
FPB10	"B" Profile - R = 10mm	194,00

FPE03	"E" Profile - 45° = 3mm	186,00
FPE05	"E" Profile - 45° = 5mm	186,00

* A richiesta • On request • Sur demande • Auf Anfrage

RAVVIVATORI PER UTENSILI DIAMANTATI • GRINDSTONE FOR DRESSING DIAMOND TOOLS

PIERRE POUR REAFFUTER LES OUTILS DIAMANTES • SCHÄRFSTEIN FÜR DIAMANTWERKZEUGE



Art. 395BJ

Art. 395B



Art.

€

395B	Stick ravvivatore (210 x 73 x 30 mm)	38,00
395BJ	Stick ravvivatore (80 x 50 x 20 mm)	12,00

MONDRILLO

PLATORELLI DIAMANTATI MULTIUSO • DIAMOND MULTIPURPOSE GRINDING WHEELS
MEULES DIAMANTEES MULTIUSAGE • MEHRZWECK DIAMANT-SCHLEIFSCHEIBE

FINE

Gres Porcellanato/Ceramica delicata/Marmo
Porcelain Stoneware/Soft Ceramic/Marble
Grés Vitrifié/Cèramique delicat/Marbre
Feinsteinzeug/ Empfindliche Keramikfliesen/Marmor



Art.	Ø		Ø		€
	mm	inch	mm		
PE115GF	115	4,5	22,2		58,00
PEBS115GF	115	4,5	M14		94,00



MEDIUM

Gres Porcellanato/Granito/Pietra/Cemento/Mattoni
Porcelain Stoneware/Granite/Stone/Concrete/Bricks
Grés Vitrifié/Granit/Pierre/Béton/Briques
Feinsteinzeug/Granit/Stein/Beton/Mauerziegel



Art.	Ø		Ø		€
	mm	inch	mm		
PE115GG	115	4,5	22,2		58,00
PEBS115GG	115	4,5	M14		94,00



MONDRILLO

MOLE DIAMANTATE PER TAGLIO E LEVIGATURA • DIAMOND CUP WHEELS FOR CUTTING AND GRINDING
MEULES DIAMANTEES POUR DÉCOUPE ET PONÇAGE • DIAMANT-SCHLEIFSCHEIBE FÜR SCHNEIDEN UND SCHLEIFEN

FINE

Gres Porcellanato/Ceramica delicata/Marmo
Porcelain Stoneware/Soft Ceramic/Marble
Grés Vitrifié/Cèramique delicat/Marbre
Feinsteinzeug/ Empfindliche Keramikfliesen/Marmor



Art.	Ø		Ø		€
	mm	inch	mm		
STL115GF	115	4,5	M14		104,00
STL125GF	125	5	M14		108,00

MEDIUM

Gres Porcellanato/Granito/Pietra/Cemento
Porcelain Stoneware/Granite/Stone/Concrete
Grés Vitrifié/Granit/Pierre/Béton
Feinsteinzeug/Granit/Stein/Beton



Art.	Ø		Ø		€
	mm	inch	mm		
STL115GG	115	4,5	M14		104,00
STL125GG	125	5	M14		108,00



PADS

PLATORELLI DIAMANTATI RESINOIDI CON ATTACCO VELCRO™ PER LA LEVIGATURA E LUCIDATURA A SECCO O AD UMIDO
 DIAMOND RESIN POLISHING PADS WITH VELCRO COUPLING FOR DRY OR WET GRINDING AND POLISHING
 MEULES DE RÉSINE DE DIAMANT AVEC FIXATION VELCRO™ POUR LE MEULAGE ET LE POLISSAGE
 DIAMANT-HARZ-SCHLEIFSCHEIBE MIT VELCRO™ ANLAGE ZUM SCHLEIFEN UND POLIEREN TROCKEN UND NASS

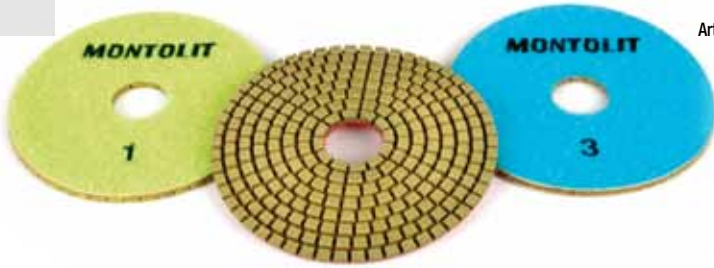

Art. PDR KIT





Art. PDR



Art. PDR 0



PDR		Gres Porcellanato/Granito Porcelain Stoneware/Granite Gres Vitrifié/Granit Feinsteinzeug/Granit			
					max rpm 4.000
Art.					€
PDR	Supporto per dischi diamantati resinoidi - M14 Support for diamond resin polishing pads - M14				30,00
PDR 0	Posizione / Step "0"				32,00
PDR 1	Posizione / Step "1"				32,00
PDR 2	Posizione / Step "2"				32,00
PDR 3	Posizione / Step "3"				32,00
PDR KIT	Posizione / Step "1 + 2 + 3"				91,00

MASTERTECH

TAMPONI DIAMANTATI PER SGROSSARE E RIFINIRE
 DIAMOND HAND PADS FOR SMOOTHING THE EDGES
 TAMPONS DIAMANTÉS POUR DEGROSSIR ET RAGRÉER
 DIAMANT-HANDPAD ZUM SCHLEIFEN UND POLIEREN



Art. DT200

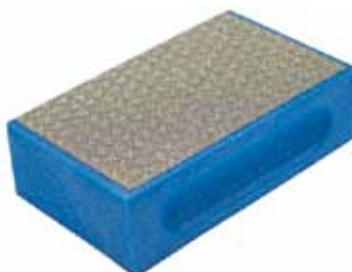

Art. DT060





FINE

MONOCOTTURA/BICOTTURA/MARMO/VETRO
 CERAMIC/DOUBLE FIRED TILE/MARBLE/GLASS
 MONOUISSON/FAIENCE/MARBRE/VERRE
 KERAMIKFLIESEN/MARMOR/GLAS









MEDIUM

GRES PORCELLANATO/KLINKER/GRANITO
 PORCELAIN STONEWARE/KLINKER/GRANIT
 GRES CERAME/KLINKER/GRANIT
 FEINSTEINZEUG/KLINKER/GRANIT

					€
					
Art.					€
DT262	Blister: 1 art. DT060 + 1 art. DT200				48,00
DT606	Box: 6 artt. DT060 - Medium				159,00
DT620	Box: 6 artt. DT200 - Fine				108,00



Art.				€
DF60	Grana/ Grit 60	- Colore/Color		38,00
DF120	Grana/ Grit 120	- Colore/Color		32,00
DF200	Grana/ Grit 200	- Colore/Color		24,00
DF400	Grana/ Grit 400	- Colore/Color		19,00
DF500	Grana/ Grit 500	- Colore/Color		17,00
DF1500	Grana/ Grit 1500	- Colore/Color		18,00
DF3000	Grana/ Grit 3000	- Colore/Color		18,00

Art.	Ø		mm	€
	mm	inch		
PUT115	115	4,5	22,2	99,00
PUT125	125	5	22,2	115,00



Art.	Ø		mm	€
	mm	inch		
PUSC100M14	100	4	M14	70,00
PUSC115	115	4,5	22,2	70,00
PUSC125	125	5	22,2	81,00
PUSC150	150	6	22,2	111,00
PUSC180	180	7	22,2	141,00



Art.	Ø		mm	€
	mm	inch		
PUSA115	115	4,5	22,2	70,00
PUSA125	125	5	22,2	81,00
PUSA180	180	7	22,2	141,00



Art.	Ø		A	€
	mm	inch		
PU100	100	4	A1: Ø 22,2mm	174,00
PU125	125	5	A2: M14	202,00
PU150	150	6	A4: W5/8"	241,00







Nella compilazione dell'ordine specificare l'attacco desiderato • When filling out your order, please specify the arbor size required
Au passage de la commande, spécifier le pas désiré • Bei Ausstellen des Auftrags, bitte die gewünschte Anschlußgröße angeben

TOTEM





ESPOSITORI MODULARI • ASSEMBLING DISPLAYS • PRÉSENTOIRS MODULAIRES • AUSTELL-MODULE



-  Condizioni particolari: contattare Agente di zona e/o ufficio vendite Brevetti MONTOLIT.
-  Please call Brevetti MONTOLIT sales department for special sales conditions.
-  Conditions spéciales: veuillez contacter le service commercial de la Brevetti MONTOLIT.
-  Für Sonderkonditionen (zB. Mengenrabatte) wenden Sie sich bitte an das Verkaufsbüro der Firma Brevetti MONTOLIT.

Art.			€
956M	Expo MASTERPIUMA (100 x 52 x 220 cm)		386,00





-  Condizioni particolari: contattare Agente di zona e/o ufficio vendite Brevetti MONTOLIT.
-  Please call Brevetti MONTOLIT sales department for special sales conditions.
-  Conditions spéciales: veuillez contacter le service commercial de la Brevetti MONTOLIT.
-  Für Sonderkonditionen (zB. Mengenrabatte) wenden Sie sich bitte an das Verkaufsbüro der Firma Brevetti MONTOLIT.



Art.			€
955T	EXPO DIAMOND BLADES (70 x 46 x 194 cm)		312,00
955B	SECURITY LOCKS/Chiusura di sicurezza (20 pcs.)		48,00



-  Condizioni particolari: contattare Agente di zona e/o ufficio vendite Brevetti MONTOLIT.
-  Please call Brevetti MONTOLIT sales department for special sales conditions.
-  Conditions spéciales: veuillez contacter le service commercial de la Brevetti MONTOLIT.
-  Für Sonderkonditionen (zB. Mengenrabatte) wenden Sie sich bitte an das Verkaufsbüro der Firma Brevetti MONTOLIT.

Art.			€
958V	CRYSTAL DISPLAY (70 x 41 x 203 cm)		590,00

ETICHETTA/MARCATURA/SIMBOLOGIA DI SICUREZZA/NORME DI RIFERIMENTO • LABEL-MARKING/SAFETY INDICATION/NORMATIVE REFERENCE
 ETIQUETTE/MARQUAGE/SYMBOLOLOGIE DE SECURITE/REGLES DE REFERENCE • ETIKETT/MARKIERUNG/SICHERHEITSHINWEISE/EUROPÄISCHE RICHTLINIE

ORGANIZZAZIONE PER LA SICUREZZA DEGLI UTENSILI ABRASIVI
 Organization for the Safety of Abrasives
 Organisation pour la Sécurité des Outils Abrasifs
 Organisation für die Sicherheit von Schleifwerkzeugen e.V.

LINEA DI PRODOTTO
 Trade Mark
 Marque de Commerce
 Handelsmarke

INDICAZIONI DI SICUREZZA
 Safety indications
 Indications de Sécurité
 Sicherheitshinweise

NOME DEL PRODUTTORE
 Manufacturer
 Producteur
 Hersteller

RESTRIZIONI D'USO
 RE6: NON AMMESSO PER LA SMERIGLIATURA
 Restrictions of use
 RE6: not permitted for face grinding
 Restrictions d'utilisation
 RE6: pas autorisé pour grésage
 Einsatzeinschränkungen
 RE6: nicht zulässig für das Schleifen

SENSO DI ROTAZIONE
 Direction of rotation
 Direction de rotation
 Drehrichtung

RESTRIZIONI D'USO
 RE1: NON AMMESSO L'USO MANUALE
 Restrictions of use
 RE1: not permitted for hand-held cutting-off
 Restrictions d'utilisation
 RE1: l'usage manuel n'est pas autorisé
 Einsatzeinschränkungen
 RE1: der manuelle Gebrauch ist nicht zulässig

MAX VELOCITÀ PERIFERICA E N° DI GIRI
 Max operating speed and max speed of rotation
 Max vitesse périphérique et max RPM
 Zulässige Umfangsgeschwindigkeit

RESTRIZIONI D'USO
 RE10: NON AMMESSO L'USO A SECCO
 Restrictions of use
 RE10: not permitted for dry cutting-off
 Restrictions d'utilisation
 RE10: l'usage à sec n'est pas autorisé
 Einsatzeinschränkungen
 RE10: der Trockenschchnitt ist nicht zulässig

CODICE LOTTO DI PRODUZIONE
 ID Production number
 Référence du lot de production
 Seriennummer

DIAMETRO E FORO CENTRALE
 Diameter and central bore
 Diamètre et alésage
 Durchmesser und Zentralbohrung

NORMATIVA EUROPEA DI SICUREZZA
 Safety European Standard
 Réglementation Européenne de Sécurité
 Europäischer Standard

MATERIALI
 Materials
 Matériaux
 Material

CODICE ARTICOLO
 Item
 Référence
 Artikel-Nr.

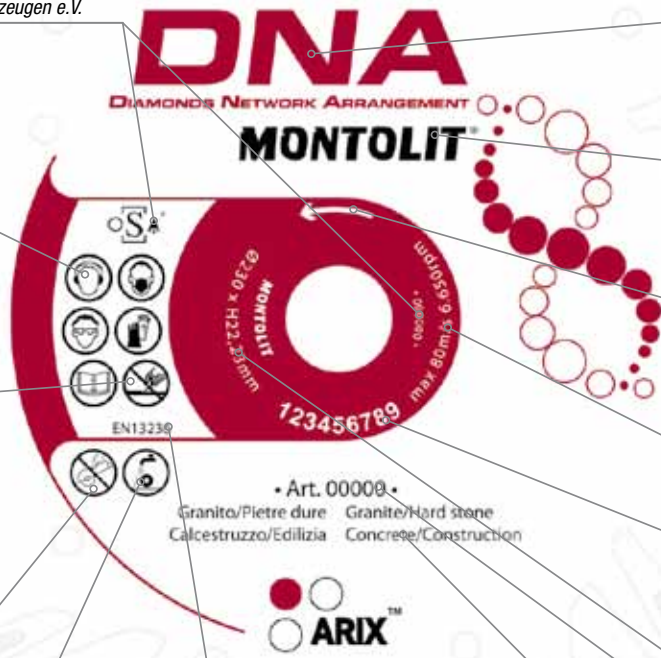

SIMBOLOGIA • SYMBOLOGY • SYMBOLOLOGIE • SYMBOLIK

	Lunghezza massima di taglio Maximum cutting length Longueur maximum de coupe Schnittlänge		Smerigliatrice angolare Electric angle grinder Ponceuses angulaires Winkelschleifmaschine		Utilizzo a secco Dry use Utilisation à sec Trockenschchnitt
	Lunghezza di taglio in diagonale Diagonal cutting length Longueur de coupe en diagonale Schnittlänge diagonal		Scanalatore Wall Chaser Rainureuse Mauernutfräse		Utilizzo a secco con aspirazione Dry use with aspiration Utilisation à sec avec aspiration Trockenschchnitt mit Saugvorrichtung
	Spessore massimo di taglio Maximum cutting thickness Épaisseur maximum de coupe Schnitttiefe		Taglierina elettrica ad acqua Electric, water-cooled diamond tilesaw Découpeuse électrique à eau Elektrische Schneidemaschinen mit Wasserkühlung		Non ammesso l'uso a secco Not permitted for dry cutting-off L'emploi à sec n'est pas autorisé Der Trockenschchnitt ist nicht zulässig
	Massima dimensione possibile Maximum dimensions Longueurs maximales Maximale Größe		Taglierina elettrica ad acqua Electric, water-cooled diamond tilesaw Découpeuse électrique à eau Elektrische Schneidemaschinen mit Wasserkühlung		Utilizzo ad umido Wet use Utilisation à eau Naßschnitt
	Potenza di spacco Power breaking Puissance de rupture Kraft		Taglierina da cantiere Slitting saw cut-off machine Tronçonneuse sur table Tischsäge für Baustellen		Non ammesso l'uso della percussione Not permitted for use with percussion drill L'emploi de la percussion n'est pas autorisé Schlagbohrmaschine ist nicht zulässig
	Peso Weight Poids Gewicht		Troncatore Cutting-off machine Tronçonneuse Trennschneider		Numero di segmenti Number of segments Quantité des segments Segmentzahl
	Potenza motore Motor power Puissance du moteur Motorleistung		Taglia pavimenti Floor cutting machine Scie à sol Fugenschneider		Spessore del disco Thickness of blade Épaisseur du disque Dicke der Scheibe
	Massimo diametro possibile Maximum diameter Diamètre maximum Maximaler Durchmesser		Elettroforatrice ad acqua Water type electrical drilling machine Perceuse électrique à eau Elektrobohrmaschine mit Wasserkühlung		Disco con flangia corazzata brevettata Blade with armour plated flange - Pat. Disque avec bride armée brevetée Scheiben mit verstärktem flansch (Pat.)
	Attacco fresa Connection for cutter Prise pour fraise Adapter für Fräser		Trapano/Carotatrice manuale Power drill Perceuse électrique portative Bohrmaschine		Disco piano Flat blade Disque plat Scheiben ohne flansch
	Diametro fresa Cutter diameter Diamètre du fraise Durchmesser Fräser		Trapano a batteria Cordless drill Perceuse sans fil Akku-Bohrschrauber		Imballo / Packing / Emballage / Verpackung
	Diametro e foro disco Blade and central bore diameter Diamètre et trou du disque Durchmesser Scheibe und Bohrung		Carotatrice professionale a telaio Professional core drilling machine with frame Machine professionnelle de carottage avec cadre Professionelle Kernbohrmaschine mit Rahmen	B = Blister C = Cartone/Carton/Carlton/Karton S = Scatola/Box/Boîte/Schachtel T = Sacchetto/Sack/Sachet/Beutel V = Non imballato/Not packed Pas emballé/Nicht verpackt 1 } Unità di vendita 2 } Sales unit 3 } ... } Unité de vente ... } Verkaufseinheit	

PIEMONTE - VALLE D'AOSTA

ROERO Rappresentanze

Via Valle Gola, 23 - 10025 PINO TORINESE (TO)
Fax (+39) 011/8119264

Sig. Roero Davide - cell. 335 5457520
email: davide@davideroero.com

Sig. Brandolini Daniele - cell. 335 236024
e-mail: danielle.brandolini@tin.it

LOMBARDIA

Prov.: **COMO, LECCO, MONZA E DELLA BRIANZA, SONDRIO, VARESE**

Sig. TRAVAGLINI MAURIZIO

Via Mulini, 1 - 21050 CANTELLO (VA)
Cell. 348 7662128 - Fax (+39) 0332/417179
email: travaglinimaurizio@virgilio.it

Prov.: **BERGAMO, BRESCIA, CREMONA, LODI, MANTOVA, MILANO, PAVIA**

B.L. Agenzia Rappresentanze s.a.s. di FRANCESCO LIONETTI & C.

Via A. Grandi, 23 - 21013 Gallarate (VA)
Tel. (+39) 0331/798816 - Fax (+39) 0331/245039
Cell. 335 1810658 - email: info@blagenzia.com

LIGURIA

Sig. ALESSANDRO DE SANCTIS

Via Recagno, 45/11 17019 VARAZZE (SV)
Tel. (+39) 019 90085 Fax (+39) 019 90085

cell. 348 3008699
email: alessanc@libero.it

TOSCANA - UMBRIA

CRAVEDI s.r.l

Via Roma, 180 - 50012 BAGNO A RIPOLI (FI)
Tel. (+39) 055/633200 - Fax (+39) 055/630240

Sig. Cravedi Carlo - cell. 335 6067155

Sig. Cravedi Iacopo - cell. 335 5429889

email: agcravedi@tiscalinet.it

MARCHE

Sig. SIMONETTI GIUSEPPE

Via San Lazzaro, 41/b - 63073 OFFIDA (AP)
Tel. (+39) 0736/880273 - Fax (+39) 0736/880273

cell. 337 637892

email: simonetti.gius@tiscali.it

LAZIO

BRA. VO. 96 di VOLPI PAOLO & C. s.a.s

Via Luigi Kossuth, 18/20 - 00149 ROMA
Tel. (+39) 06/55260370 - Fax (+39) 06/55260370
email: bravosas96@gmail.com

SARDEGNA

FERRAMENTA BISCIONE di BRUNO PAOLO & C. s.a.s.

Via Dante, 90 - 20092 CINISELLO B.(MI)
Tel. (+39) 02/6181326 - Fax (+39) 02/6126757

Sig. Bruno Paolo - cell. 335 6934945
email: brunorappresentanze@libero.it

VENETO - TRENTINO ALTO ADIGE

SONTACCHI LUCA Rappresentanze

Via Venier 101 - 35127 PADOVA (PD)
Fax (+39) 049/851798

Sig. Sontacchi Luca - cell. 348 3335446
email: sontacchiluca@libero.it

FRIULI VENEZIA GIULIA

SONTACCHI LUCA Rappresentanze

Via Venier 101 - 35127 PADOVA (PD)
Fax (+39) 049/851798

Sig. Fabiani Stefano - cell. 348 2389760
email: stefano.fabiani@alice.it

EMILIA ROMAGNA

S. P. TRADING s.r.l

Via E. Cabassi, 6 - 41012 CARPI (MO)

Sig. Scacchetti Luca - cell. 335 8142852
email: 86scacco63@gmail.com

ABRUZZO - MOLISE

Sig. CANDELORI BENIAMINO

Via De Gasperi, 1 - 66020 SAN GIOVANNI TEATINO (CH)

cell. 335 6953141
email: candelorib@tiscali.it

CAMPANIA - BASILICATA (Provincia di POTENZA)

Sig. LUCARIELLO ROBERTO

Via Matteotti, 23 - 80046 S. GIORGIO A CREMANO (NA)
Tel. (+39) 081/7754057 - Fax (+39) 081/7754057

cell. 339 6447436
email: robertolucariello@gmail.com

PUGLIA - BASILICATA (Provincia di MATERA)

SCARINGELLA Rappresentanze di SCARINGELLA ALESSANDRO & C. s.a.s

Seconda traversa via Pizzillo, 10/5 - 70128 BARI
Fax (+39) 080/5300220

cell. 335 6441295
email: scaringella.rappresentanze@gmail.com

CALABRIA

Sig.ra FRATTO ELISABETTA

Via Calabretta, G/3 - 88068 SOVERATO (CZ)
Tel. (+39) 0961/762805 - Fax (+39) 0961/762805

cell. 3356797443
email: frattoelisabetta@tiscali.it

SICILIA

Sigg. LUPO Dott. CLAUDIO & LUPO Dott. ALDO

Via G. D'annunzio, 19 - 95037 TRAPPETO DI S. G. LA PUNTA (CT)
Tel. (+39) 095/7176542 - Fax (+39) 095/7179417

Sig. Lupo Dott. Claudio - cell. 339 8808588
email: lupo53c@libero.it

Sig. Lupo Dott. Aldo - cell. 345 8472202
email: aldolupo7@alice.it



GENERAL TERMS OF SALE

THIS PRICE-LIST CANCELS AND REPLACES FORMER ONES

By placing the order the customer accepts without reserve the following conditions:

- 1) Goods are delivered ex our warehouse in Cantello (VA) - Italy.
- 2) Upon customer's request for a delivery: EX ITALIAN WAREHOUSE - F.O.B. - C&F - C.I.F. - or other ones to a place of his choice, the cost of either one of these deliveries will be invoiced to him.
- 3) Goods travel at consignee's risk even if under terms of sale: free place of destination.
- 4) Complaints for defects or statements of shortage of goods will be taken into consideration within 8 days from receipt of the goods, without prejudice to the disposition on point 3.
- 5) PAYMENTS MUST BE ABSOLUTELY CARRIED OUT WITHIN THE AGREED UPON TERMS.
- 6) The cost for special packing will be invoiced at cost price.
- 7) Foreign bank charges will be charged to the customer's account.
- 8) Any dispute between the parties will be submitted TO ARBITRATION IN VARESE (ITALY) before the competent COURT under its rules.

* WARRANTY

MACHINES AND EQUIPMENT: all MONTOLIT tools are covered by a 2 (two) years warranty starting from the date of sale (proof provided by an invoice, delivery note or fiscal receipt). Manually operated tile cutters, tile drills, block cutters and roof tile cutters are covered by a lifetime warranty (claims allowed at the sole discretion of Brevetti MONTOLIT S.p.A. Engineering Department) in respect of construction defects. Defects resulting from improper use or from normal wear and tear are excluded from the terms of these warranties.

DIAMOND TOOLS: it is wholly acknowledged by Brevetti MONTOLIT S.p.A. Technical Office, for discs barely used and not yet worn out, which present clearly visible manufacturing defects. This guarantee does not cover discs used for cutting materials different from the ones they have been manufactured for. Complaints on any delivered diamond cutting discs will only be accepted if the wear of the rim height does not exceed 20%.

Brevetti MONTOLIT has always employed and supplied top quality materials and products. Our professional commitment to our customers places us well above the common standard. We take great pride in the safety and reliability of our products. Commitment to quality is not just an idle boast-our products are covered by full written warranties. In fact, we insure all our products against accidental damage due to manufacturing defects and poor workmanship after sale and delivery.



CONDITIONS GENERALES DE VENTE

LE PRESENT TARIF ANNULE ET REMPLACE TOUS LES PRECEDENTS

En passant une commande, s'entendent comme acceptées les conditions suivantes, sans aucune réserve de votre part:

- 1) La marchandise est livrée franco départ nos entrepôts de Cantello (VA), Italie.
- 2) Sur demande du client, sera facturé le coût total pour livraison: FRANCO DEPOT ITALIEN - à la place indiqué par le client, ou pour livraison F.O.B. - C&F - C.I.F. - ou toute autre condition de livraison demandée.
- 3) La marchandise voyage aux risques et périls du destinataire, même si sous conditions FRANCO à DESTINATION.
- 4) Les plaintes pour défaut éventuels ou les constatations de manquant en marchandise, seront prises en considération dans les 8 jours dès la réception de la marchandise, sans préjudice de ce qu'on a décrit au point 3.
- 5) LES PAIEMENTS SONT A EFFECTUER FORMELLEMENT DANS LES DELAIS CONVENUS.
- 6) Les frais d'emballages spéciaux seront facturés au prix coûtant.
- 7) Les frais de banque étranger seront portés à la charge du client.
- 8) En cas de contestation, le TRIBUNAL DE VARESE (ITALIE) est le seul compétent et la LOI à APPLIQUER sera la LOI ITALIENNE.

* GARANTIE

MACHINES ET OUTILLAGE: une garantie de 2 (deux) ans à compter de la date de vente (facture/bulletin de livraison/reqû fiscal) s'applique à tous les équipements MONTOLIT. Les machines manuelles à couper les carreaux, à percer les carreaux, à couper les blocs et les tuiles bénéficient d'une garantie à vie sur les défauts éventuels de construction (reconnue par un jugement sans appel du Service Technique de "Brevetti MONTOLIT S.p.A."). Les pannes qui dériveraient d'un usage non conforme ou d'une usure normale sont exclues de ces garanties.

OUTILS DIAMANTES: la garantie joue totalement suivant l'avis du Bureau Technique de la Brevetti MONTOLIT S.p.A. pour les disques venant d'être utilisés et ne pas détériorés, qui présentent des défauts de fabrication. Cette garantie ne joue d'avantage pour des disques détériorés suivant la coupe de matériaux différents à ceux pour lesquels ils ont été produits. Les réclamations peuvent être traitées uniquement lorsque l'usure de la jante diamantée ne dépasse pas le 20%.

Depuis toujours Brevetti MONTOLIT utilise et fournit du matériel d'excellente qualité. Notre entreprise est caractérisée par un sérieux professionnel et commercial qui va bien au-delà des standards. En effet, la sécurité et la garantie du produit font notre orgueil. Mais nous ne nous arrêtons pas aux mots car nous offrons à notre clientèle des garanties écrites: nous assurons tous nos produits contre tout dommage accidentel pouvant résulter d'un défaut de construction et fabrication même après la livraison et la commercialisation.



ALLGEMEINE VERKAUFSBEDINGUNGEN

DIESE PREISLISTE ANNULLIERT UND ERSETZT DIE VORHERIGEN PREISLISTEN

Mit der Auftragsvergabe gelten die folgenden Bedingungen als ohne Vorbehalte von dem Auftraggeber akzeptiert.

- 1) Die Ware wird ab unserem Werk in Cantello (VA) Italien geliefert.
- 2) Auf Wunsch des Auftraggebers werden die Gesamtkosten für folgende Lieferungen in Rechnung gestellt: FREI AB ITALIENISCHEM von dem Auftraggeber angegebenen WERK für die vorläufige Lagerung der Ware für die Liederung oder F.O.B., C&F oder C.I.F. sowie für andere Lieferbedingungen.
- 3) Die Ware reist auf Gefahr des Auftraggebers, selbst wenn sie FREI BESTIMMUNGSORT reist.
- 4) Etwaige Beanstandungen für fehlerhafte Ware oder Mitteilungen von Warenfehler werden innerhalb 8 Tagen vom Wareneingang berücksichtigt, unter Beibehaltung oder zu Punkt 3 beschriebenen Bedingungen.
- 5) ZAHLUNGEN SOLLEN UNBEDINGT ZU DEN VEREINBARTEN TERMINEN GELEISTET WERDEN.
- 6) KOSTEN FÜR SONDERVERPACKUNGEN werden zum Selbstkostenpreis in Rechnung gestellt.
- 7) Die Bankgebühren der ausländischen Bank gehen zu Lasten des Auftraggebers.
- 8) Für jede Streitigkeit ist das GERICHT VON VARESE (ITALIEN) ausschließlich zuständig und das AND-WENDBARES RECHT wird das ITALIENISCHE sein.

* GARANTIE

MASCHINEN UND AUSRÜSTUNGEN: für alle Ausrüstungen von MONTOLIT wird eine Garantie von 2 (zwei) Jahren ab Verkaufsdatum (Rechnung / Lieferschein / Kassenzettel) gewährt. Eventuelle Fabrikationsfehler der Fliesenschneider, Fliesen-Lochsneider, Blocksneider und manuellen Ziegelschneidmaschinen sind mit einer (nach unanfechtbarem Ermessen des Technischen Büros der Firma Brevetti MONTOLIT S.p.A. anerkannten) Garantie auf Lebensezeit gedeckt. Durch unsachgemäße Benutzung oder normalen Verschleiß verursachte Schäden sind von diesen Garantieleistungen ausgeschlossen.

DIAMANTWERKZEUGE: wenig verwendete und noch nicht verschlissene Scheiben, die offensichtliche Fabrikationsfehler haben werden nach Ermessen der Technischen Abteilung der Firma Brevetti MONTOLIT S.p.A. völlig ersetzt. Scheiben, die beschädigt worden sind, weil sie für nicht geeignete Materialien verwendet wurden, werden nicht ersetzt. Beanstandungen von gelieferten Diamant-Trennscheiben können nur bis zu einem Verbrauch von 20% der Belag- bzw. Segmenthöhe angenommen werden.

Das Unternehmen Brevetti MONTOLIT fühlt sich dem hohen Qualitätsanspruch seiner Kunden stets verpflichtet. Aus diesem Grunde verwenden und liefern wir seit jeher nur Erzeugnisse von ausgezeichneter Qualität. Unsere Geschäftspraxis beruht jedoch nicht nur auf Worten, sondern stützt sich auf eindeutige schriftliche Garantien. Unsere Erzeugnisse sind gegen unwillkürlich verursachte Schäden versichert, die durch einen Konstruktionsfehler entstanden sind. Dies gilt auch nach Lieferung und Verkauf.



CONDIZIONI GENERALI DI VENDITA

IL PRESENTE LISTINO ANNULLA E SOSTITUISCE I PRECEDENTI

L'ordine s'intende conferito od assunto "salvo approvazione della casa" e tale approvazione viene anche manifestata con la sola pratica evasione dell'ordine stesso.

Con il conferimento dell'ordine si intendono accettate, senza riserve, da parte del committente, le seguenti condizioni:

- 1) Resa: franco partenza nostre officine di Cantello con spedizione in:
 - a) porto franco - con addebito in fattura - se il trasporto viene effettuato tramite corrieri con noi convenzionati.
 - b) porto assegnato - qualora venga richiesto dal cliente il trasporto con corriere diverso da quello con noi convenzionato.
- 2) Per eventuali richieste di spedizioni con caratteristiche diverse dalle abituali (es.: pacco postale, espresso, pacco aereo, ecc.) il costo verrà addebitato secondo tariffe da noi stabilite.
- 3) Gli ordini vengono evasi secondo le disponibilità di magazzino, senza garanzie di saldo. Le eventuali rimanenze saranno inviate appena disponibili. Trascorsi 90 gg. dalla data di prima spedizione, ogni rimanenza inevasa sarà annullata.
- 4) Le illustrazioni, le caratteristiche e tutte le altre indicazioni descritte sul catalogo s'intendono approssimative, riservandoci di apportare tutte quelle modifiche che, a nostro giudizio, costituiscono migliorie, senza che ciò possa giustificare reclamo da parte del committente.
- 5) La merce viaggia a rischio e pericolo del committente, anche se venduta franco destino; pertanto per ogni ammanco, per eventuali ritardi e per ogni disguido, dovrà essere rivolto reclamo al vettore unico responsabile. Si raccomanda di controllare lo stato della merce, i pesi e il n° colli prima di prendere in consegna la merce. Da parte nostra, daremo tutta la collaborazione possibile per mettere il committente in condizioni di presentare reclamo.
- 6) Eventuali lamentele per difetti saranno prese in considerazione solo entro otto giorni dal ricevimento della merce.
- 7) I pagamenti dovranno essere effettuati, nei termini concordati, esclusivamente alla nostra sede o a persone da noi autorizzate e non sono ammesse trattative arbitrarie ed arrotondamenti. Per i pagamenti ritardati saranno conteggiati interessi di banca.
- 8) Trascorsi 30 gg. dal termine di pagamento s'intende revocato ogni sconto di pagamento e pertanto le fatture dovranno essere pagate per intero.
- 9) I materiali sono garantiti per qualità e lavorazione. Ciò comporta la loro sostituzione o accredito, a nostro giudizio, la loro riparazione, a condizione che:
 - a) il reso ci pervenga in porto franco, altrimenti verrà respinto;
 - b) i materiali presentino evidenti difetti di costruzione e di qualità che dovranno essere indicati sulla bolla che accompagna il reso. **SULLA STESSA É INDISPENSABILE INDICARE ANCHE IL RIFERIMENTO DELLA FORNITURA (N° FATTURA, DATA, ECC.), SECONDO LE VIGENTI DISPOSIZIONI FISCALI;**
 - c) non saranno sostituiti, né riparati gratuitamente, restando a disposizione del committente, i prodotti che risultassero guastati per imperizia o manomissione o per adattamento ad usi diversi da quelli ai quali sono destinati.
- 10) La garanzia esclude qualsiasi rivalsa per danno e spese di ogni genere.
- 11) **RESI DI MERCI PER ERRORI DI ORDINAZIONE O PER MOTIVI NON IMPUTABILI ALLA BREVETTI MONTOLIT, SARANNO ACCETTATI SOLO SE:**
 - PREVENTIVAMENTE AUTORIZZATI DALLA DIREZIONE E SPEDITI IN PORTO FRANCO;
 - LA MERCE RESA DOVRÀ ESSERE INTATTA, SIGILLATA NELLA CONFEZIONE ORIGINALE E NON ACQUISTATO DA OLTRE 12 MESI. LA MERCE RESA, SE RISCONTRATA IN PERFETTO STATO, SARÀ ACCREDITATA NEL VALORE FATTURATO MENO IL 10% QUALE CONCORSO SPESE PER LE OPERAZIONI AMMINISTRATIVE, CONTROLLO E REIMMAGAZZINAGGIO. PER ECCEZIONALI RESI DI MERCE ACQUISTATI DA OLTRE 12 MESI, SARÀ INDISPENSABILE RICHIEDERE LA PREVENTIVA AUTORIZZAZIONE ALLA DIREZIONE DELL'AZIENDA CHE ESPRIMERÀ PARERE INSINDACABILE CIRCA L'ACCETTAZIONE DEL RESO STESSO E LA RELATIVA QUOTAZIONE.
- 12) I.V.A., tasse ed ogni altro onere fiscale sono a carico del committente.
- 13) Per qualsiasi contestazione si riconosce esclusiva competenza al TRIBUNALE DI VARESE.

ATTENZIONE:

- Per ogni ordinazione indicare sempre il numero di articolo.
- Per ogni ordinazione attenersi all'unità di vendita e relativo multiplo. La casa si ritiene autorizzata a modificare d'ufficio eventuali quantità non corrispondenti all'unità di vendita.

* GARANZIA

MACCHINE ED ATTREZZATURE: per tutte le attrezzature MONTOLIT é riconosciuta una garanzia di 2 (due) anni a partire dalla data di vendita (fattura / bolla di consegna / scontrino fiscale). Tagliapiastrelle, forapiastrelle, tranciacblocci e tagliategole manuali sono coperti da garanzia a vita su eventuali difetti di costruzione (riconosciuti a giudizio esclusivo dell'Ufficio Tecnico della Brevetti MONTOLIT S.p.A.). Guasti derivanti da un uso non conforme o da normale usura sono esclusi dalle presenti garanzie.

UTENSILI DIAMANTATI: viene riconosciuta totalmente, a giudizio dell'Ufficio Tecnico della Brevetti MONTOLIT S.p.A., su dischi appena usati e non ancora consumati che presentino evidenti difetti di fabbricazione. La garanzia non verrà riconosciuta per i dischi deteriorati in seguito al loro uso per tagli di materiali diversi da quelli per i quali sono stati specificatamente prodotti. Reclami riguardanti qualsiasi disco da taglio consegnato saranno accettati solamente se il consumo dell'altezza della fascia diamantata non abbia superato il 20%.

Da sempre, la Brevetti MONTOLIT impiega e fornisce materiali di prima scelta. Si tratta di un impegno di serietà e moralità commerciale che eleva la Nostra Azienda al di sopra dello standard. Sicurezza e garanzia del prodotto costituiscono per noi motivo di vanto. Una realtà operativa che non è fatta solo di parole, ma anche di vere e proprie garanzie scritte. Infatti assicuriamo tutti i nostri prodotti contro i danni involontariamente cagionati in conseguenza di un fatto accidentale verificatosi per difetto di costruzione e fabbricazione del prodotto anche dopo la sua consegna e commercializzazione.



SINCE 1946

Brevetti Montolit S.p.A.

Sedi operative/*Company headquarters:*
Largo Cav. Montoli - 21050 Cantello (VA) Italy
Via Varese 4/A - 21050 Cantello (VA) Italy

Sede legale/*Legal head office:*
Via Turconi, 25 - 21050 Cantello (VA) Italy

Tel. ++39 0332 419 211
Fax ++39 0332 418 444

www.montolit.com
info@montolit.com

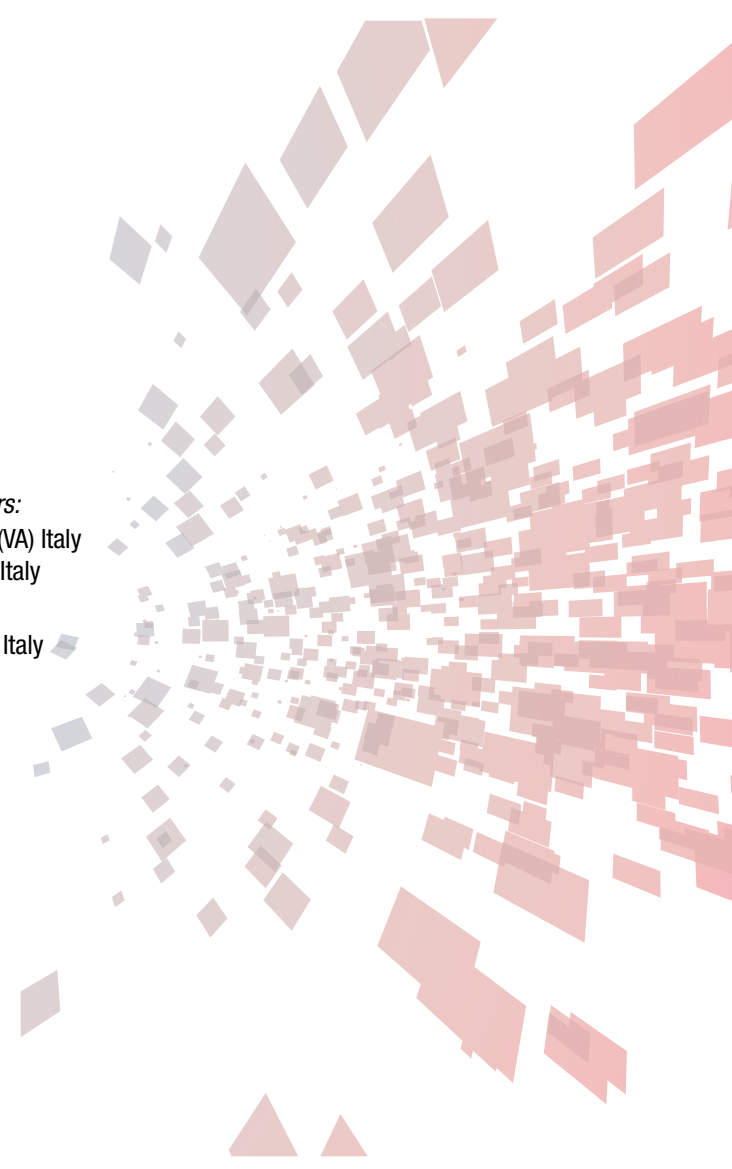

Montolit is technical partner of:

**SPV
ASC
ASP**



Schweizerischer Plattenverband
Association Suisse du Carrelage
Associazione Svizzera delle Piastrelle
Switzerland Association of Tiles



**LIFETIME
WARRANTY**

**2
YEARS**

* *Informations*
pag. 83

Distributore autorizzato | *Authorised dealer* | Distributeur autorisé | *Autorisierter Händler*

